

[www.dessin-project.eu](http://www.dessin-project.eu)

## **D21.1 Treatment Units and Instrumentation for CSO Treatment Solutions**

**Final Report on Model Tests  
with the Cross-Flow Lamella Settler Prototype**

**Gebhard Weiss, UFT, May 2015**



The research leading to these results has received funding from the European Union Seventh Framework Programme (FP7/2007-2013) under grant agreement no. 619039

This publication reflects only the author's views and the European Union is not liable for any use that may be made of the information contained therein.

## SUMMARY

Deliverable D21.1 is defined as a prototype of 'Treatment units and instrumentation for CSO treatment solutions'. According to FP7 definitions, a prototype is 'intended as a man-made object which shows the scientific and technical feasibility of a concept' (EC, 2014). As such, it can not be submitted or distributed, but this report describes and documents the model setup and findings of thorough model tests on a prototype of a cross-flow lamella settlers. This type of plate settler is claimed to show less sediment re-mixing compared to the more common upflow or counter-current settlers. The objective of the model tests using spherical plastics beads as model sediment was to investigate basically the behaviour of sediments and to establish efficiency curves for a given flow and sediment characteristics. The experiments were conducted using tap water as well as salt water of different density in order to vary the settling velocity as the most essential parameter. Steady-flow efficiency curves were gained which showed that the efficiency decreases with increasing surface load as well as with decreasing settling velocity. The evaluation was made in dimensionless form to allow scaling and possibly transfer to prototype size. Comparison with similar curves from upflow lamella model experiments was possible under some assumptions, but only slightly better efficiency could be obtained. One essential fact is the coaction of the settler modules and the vessel in which they are placed. Moreover, the results indicated that there is still re-mixing of already settled sediments into the flow. Generally, it was found that the overall sediment removal efficiency of a lamella settler is not governed by the sedimentation process only, but also to a large part by secondary effects such as by the flow-induced sediment transport on the settler surfaces and, particularly for real sewage sediments, by sticking to lamella surfaces and by formation of sediment flakes affecting sliding-down. This makes it difficult to predict the performance of real lamella settlers from model test data reliably. However, some findings indicate that the prototype efficiency will be considerably better than derived from model data.

## DELIVERABLE NUMBER

D21.1

## WORK PACKAGE

WP2.1

## LEAD BENEFICIARY

UFT Umwelt- und Fluid-Technik GmbH

## DELIVERABLE AUTHOR(S)

Gebhard Weiss, UFT

## QUALITY ASSURANCE

Doris Steinriede  
Herman Helness

UFT  
SINTEF

## PLANNED DELIVERY DATE

31/10/2014

## ACTUAL DELIVERY DATE

22/05/2015

## DISSEMINATION LEVEL

- PU = Public  
 PP = Restricted to other programme participants  
 RE = Restricted to a group specified by the consortium.  
Please specify: \_\_\_\_\_  
 CO = Confidential, only for members of the consortium



TABLE OF CONTENTS.....	II
LIST OF FIGURES .....	IV
LIST OF TABLES.....	VI
LIST OF ACRONYMS AND ABBREVIATIONS.....	VII
EXECUTIVE SUMMARY.....	1
1 INTRODUCTION.....	2
1.1 <i>About DESSIN work package WP 21</i> .....	2
1.2 <i>Use of lamella settlers in urban drainage: State of the Art</i> .....	2
1.3 <i>Recent research project on upflow lamella settlers</i> .....	4
2 CROSS-FLOW LAMELLA SETTLING: SOME THEORETICAL CONSIDERATIONS.....	7
2.1 <i>Basic sedimentation theory</i> .....	7
2.2 <i>Dimensional analysis</i> .....	9
3 MODEL TESTS ON CROSS-FLOW LAMELLA SEPARATORS .....	12
3.1 <i>Experimental setup</i> .....	12
3.2 <i>Experimental program</i> .....	14
3.2.1 <i>Qualitative tests of flow pattern</i> .....	14
3.2.2 <i>Model sediment</i> .....	15
3.2.3 <i>Determination of steady-flow settling efficiency</i> .....	15
3.2.4 <i>Test runs</i> .....	17
4 RESULTS .....	19
4.1 <i>Steady-flow efficiency vs. flow</i> .....	19
4.2 <i>Dimensionless plots</i> .....	19
5 EXPERIMENTS WITH “TAIL STRIPS” ON THE LAMELLA PLATES .....	30
5.1 <i>Experimental set up and observations</i> .....	30
5.2 <i>Results</i> .....	31
6 EXPERIMENTS WITH HORIZONTAL PLATE SETTLERS.....	33
6.1 <i>Experimental setup and observations</i> .....	33
6.2 <i>Results</i> .....	35
7 COMPARISON WITH RESULTS FOR UPFLOW LAMELLA SEPARATORS .....	38



8	LESSONS LEARNED .....	44
9	REFERENCES .....	46



Figure 1: Upflow, downflow, cross-flow and horizontal plate settlers (from left to right).....	3
Figure 2: Model test rig of the past experiments on an upflow lamella separator (from KIT 2015b).....	4
Figure 3: Section drawing of the upflow lamella container .....	5
Figure 4: Upflow lamella container. Left: Top view with lamella modules and overflow system. Right: Container in place. In the foreground the feeding pump in the inlet flume of a treatment plant and one of the 1000 L samplers .....	6
Figure 5: Definition sketch .....	8
Figure 6: Final design of the experimental flume with two cross-flow lamella modules .....	13
Figure 7: Schematic setup of the experiments .....	14
Figure 8: Left: Overflow fabric sieve for recovery of model sediment (the round coarser sieves above acted as antispash protection only). Right: Imhoff cones for determination of sediment volume after 24 h of settling .....	16
Figure 9: Direct plot of steady-flow separation efficiency vs. flow.....	19
Figure 10: Dimensionless plot of settling efficiency.....	20
Figure 11: Results for 2 modules and 80 mm spacing. Top: The tests with particularly high density show numerous “outliers” with overestimated efficiency. Below: Same diagram, but with outliers removed and enlarged abscissa scale.....	21
Figure 12: Results for 2 modules and 40 mm lamella spacing. Here, a more or less unique curve can be seen.....	22
Figure 13: Comparison of results for 1 module with 40 mm and 2 modules with 80 mm lamella spacing (approximately equal projected lamella surface). The cluster is scattered, but it shows also a rather unique relationship.....	22
Figure 14: Comparison of results for 2 modules and 80 mm and 40 mm lamella spacing. Two distinct different patterns can be distinguished here.....	23
Figure 15: Using the different abscissa parameter, the test results of all configurations show nearly no significant separate patterns.....	24
Figure 16: Same as Figure 15, but only with tests with density 1 kg/L.....	25
Figure 17: Approximation of data points by a single curve .....	26
Figure 18: Same as Figure 17, but for other settler geometries.....	26
Figure 19: Apparent increase in settling area vs. ratio of lamella and flume surface .....	27
Figure 20: The trailing edge of the second lamella module during a test. A lot of sediment has settled on the inclined surfaces. A considerable number of grains are transported by the flow over the edge.....	29



Figure 21: Close look on the “tail strips” of the second lamella module during the test. Some sediment grains are trapped by the strip, while others skip over it, transported by the flow.....	30
Figure 22: Raw data of efficiency vs. flow for modules with “tail strips”. All tests were made with $h_L = 40$ mm and two modules.....	31
Figure 23: Dimensionless plot including a fitted synthetic curve.....	32
Figure 24: Two horizontal plate settlers in place.....	33
Figure 25: (above and right): Horizontal plate settler, 2 modules, $h_L = 80$ mm, $Q = 4,0$ L/s. Evolution of sediment dunes with time. Left: 30 min, right: 60 min after beginning of test.....	34
Figure 26 (left): Horizontal plate settler, 2 modules, $h_L = 80$ mm, $Q = 4,0$ L/s. Trailing edge view. Sediment is transported over the smooth horizontal surfaces and re-mixed into the flow.....	34
Figure 27: Raw data of efficiency vs. flow for a horizontal plate clarifier (two modules, $h_L = 80$ mm).....	35
Figure 28: Comparison of a horizontal plate clarifier with cross-flow clarifiers, both for a total projected area of $A_{proj,tot} = 4.2$ m <sup>2</sup> and 4.4 m <sup>2</sup> , respectively, and in the same experimental rig.....	35
Figure 29: Modelled curve and data set for the horizontal lamella settlers.....	36
Figure 30: Settling efficiency of an upflow lamella separator as function of $q_A/v_s$ (from KIT 2015b).....	39
Figure 31: Comparison of cross-flow and upflow lamella settler efficiencies, both with approximately equal settling areas ( $A_{proj,tot} = 4.4$ m <sup>2</sup> at 40 mm lamella spacing and 2.2 m <sup>2</sup> at 80 mm, for both types).....	39
Figure 32: Comparison of cross-flow and upflow lamella settler efficiencies, other abscissa, including fitted synthetic curves.....	40
Figure 33: Apparent increase in settling area for cross-flow and up-flow lamella separators. The abscissa is the ratio of projected settler surface to the plan surface of the tank or vessel in which the lamellae are inserted.....	41



Table 1: Compilation of test runs .....	18
Table 2: Apparent increase in settling surface if lamella settlers are installed .....	27
Table 3: Technical data of model tests from KIT (2015b) with upflow lamella settlers .....	38
Table 4: Comparison of apparent increase of settling area for upflow and up flow lamella separator tests.....	41



## List of Acronyms and Abbreviations

- CSO combined sewer overflow, structure in a combined sewer system which releases excess flow during a storm directly into the receiving waters
- CSO tank structure within a combined sewer system which has the task of storage and /or treatment of overflowing water by sedimentation, both reducing the pollutant load on the receiving waters considerably





The present report describes the model tests on a prototype for cross-flow lamella settlers within the project DESSIN. After some theoretical background on the lamella settler, the model setup and evaluation method are described and documented. The model tests were conducted in a reduced-scale model, but using prototype settler plate spacing. Spherical plastics beads were used as model sediment. The removal efficiency could be obtained easily by sieving-out of the material and determining the volume in Imhoff cones. Several different plate configurations were tested. In order to vary the settling velocity, salt was added to the water in a couple of test runs.

Cross-flow lamella settlers are claimed to show less sediment re-mixing compared to the more common upflow or counter-current settlers. The objective of the model tests was to investigate basically the behaviour of sediments and to establish efficiency curves for a given flow and sediment characteristics.

As primary result, steady-flow efficiency curves were gained which showed that the efficiency decreases with increasing surface load as well as with decreasing settling velocity. The evaluation was made in dimensionless form to allow a possible transfer to prototype size.

Comparison with similar curves from counter-current model experiments, however, proved to be difficult. Only slightly better efficiency could be obtained. One essential fact is the coaction of the settler modules and the vessel in which they are placed. In the model tests, it is not possible to separate the influence of both. Moreover, the results indicated that there is still re-mixing of already settled sediments into the flow at the tail edges of the plates (this effect was dominating at upflow settlers because there any sediment sliding down is re-mixed into the inflow).

Different from reported in most literature on lamella settlers, it was found that the sediment removal efficiency is not governed by the sedimentation process only, but also by secondary effects which are crucial, if not dominating. These comprise e.g. the flow-induced sediment transport on the settler surfaces. Furthermore, and particularly when comparing model and real sewage sediments, sediment properties other than the settling velocity play an essential role. This is e.g. sticking of the sediment to the lamella surfaces and also spontaneous formation of sediment flakes which affect the sliding-down behaviour. These effects make it difficult, if not impossible, to predict the performance of real lamella settlers from model test data.

Results from a former research project on upflow settlers indicate that the prototype efficiency might be considerably better than derived from model data. It is thus essential that this is proved by careful and thorough evaluation of the settling efficiency results which we expect in the DESSIN prototype lamella settler container tests at Emscher and Hoffselva.

## 1.1 About DESSIN work package WP 21

Within the states of the European Community, most municipalities are today connected to biological wastewater treatment plants (WWTP) with good (and continuously improved) cleaning efficiency. Thus, the remaining pollution emissions from stormwater outlets and particularly also from non-treated combined sewage overflows (CSOs) form an increasing percentage of the total emissions. Within the European research project DESSIN, ecosystem services (ESS) are the focus of interest, including investigations of several innovations how to improve the ecosystem. The implementation of the EC Water Framework Directive (WFD 2000) also encourages innovative methods to minimize emissions and thus enhance also the ecosystem services. Within DESSIN, a specific ESS approach shall be applied to evaluate the effect of these innovations.

In the DESSIN Work Packages WP 21, WP 31 and WP 32, the application of innovative cross-flow lamella settlers for enhancement of treatment of combined sewer overflows is the focus of interest. Work Package WP 21 first comprises model tests on cross-flow lamella settlers in order to gain insight in the settling process in such devices. The model tests should reveal data on the settling behaviour of idealized model sediment and allow a comparison to results from a recently completed research project on upflow lamella separators. Anyhow, model investigations may reveal basic insights, but cannot account for the behaviour of real sewage-borne sediments, so full-scale investigations are essential, too. Within the work packages WP 31 and WP 32, a mobile full-scale lamella settler treatment unit is constructed which allows prototype investigations at real combined sewer overflow structures, in the German Emscher region (WP 31) as well as in Norway at Hoffselva (WP 32). This mobile unit will also allow an evaluation by use of the ESS approach.

This final report of Work Package WP 21 describes the model tests conducted by the DESSIN project partner UFT. After some basics on lamella settlers and also a short theoretical approach on settling in a lamella unit, the experimental setup is described and the results are documented and discussed. A further chapter compares the model test results of the cross-flow lamella settler to up-flow units which were investigated in a recently completed research project.

## 1.2 Use of lamella settlers in urban drainage: State of the Art

Lamella settlers are tried-and-tested sedimentation devices in process technology (e.g. mining, quarries, etc.). The principle is used in many commercial devices. The basic idea is to feed the sediment-laden flow through narrow gaps between plates in order to provide a merely small settling distance of some cm, rather than of the whole depth of a settling tank. Lamellas also increase the effective area of the settler and thereby reduce the surface load. This will increase the settling efficiency considerably. Plate or honeycomb arrays made from plastics or other materials come in a variety of dimensions and shapes from different manufacturers.

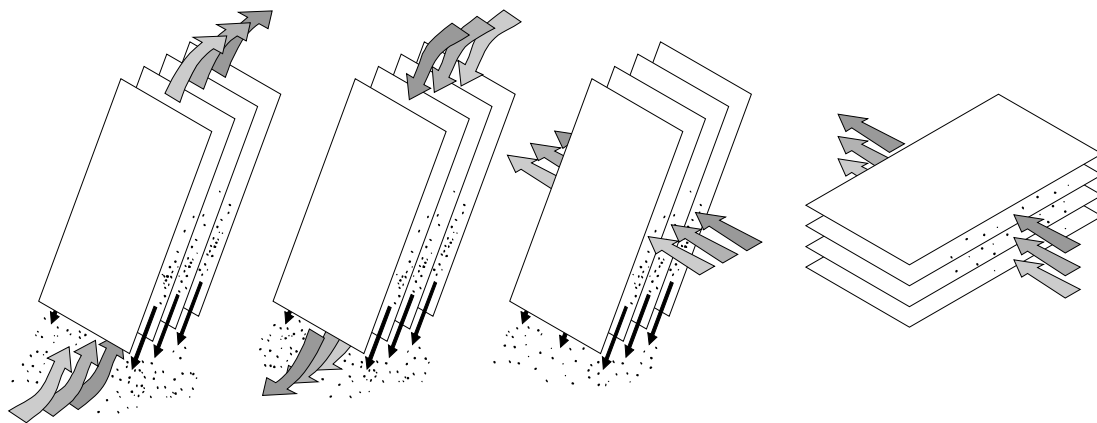

Figure 1: Upflow, downflow, cross-flow and horizontal plate settlers (from left to right)

Figure 1 shows basic arrangements for lamella settlers made from plate arrays. Except the horizontal plate settler, the plates are inclined to allow the settled sludge to slide finally down into a sludge sump from where it can be removed. Of course, there are numerous ideas and patents for cleaning the whole assembly. Most popular are upflow settlers. In this case, also honeycomb profiles or tube arrays are used. Cross-flow settlers are used less frequently. They are made from plates, either flat or corrugated. Their advantage is that sediments which are sliding down laterally do not mix with the inflow, an effect which occurs rather pronouncedly in model tests with upflow settlers. In the present project DESSIN, cross-flow plate settlers are investigated.

The lamella settler technique (of any type from Figure 1) has been applied in the past years in several research or demonstration projects for cleaning of storm runoff from separate drainage systems and also for treatment of combined sewage, e.g. overflow from CSO tanks. The latter field of application is the focus of the present research project DESSIN.

Lamella settlers have been used frequently on treatment plants, e.g. in aeration tanks (Schönberger et al. 2001) or in order to improve the sludge separation in secondary settling tanks (Dorgeloh et al. 1996, Buer und Dorgeloh 2001, Fujisaki 2010). There had been also a workgroup of the German Association for Water, Wastewater and Waste (DWA, formerly ATV), which issued a report already 35 years ago in 1980 (ATV 1980).

Fewer projects used lamella settlers for stormwater and CSO treatment. Krauth and Bondareva (1999) investigated the use of flocculants also for stormwater treatment and proposed lamella sedimentation for flake removal. In the German federal land of Baden-Württemberg, three pilot projects were conducted (Brühl and Göbrichen in combined systems, Pforzheim Klingklamm in a separate system); cf. Fuchs und Mayer (2010), Fuchs et al. (2010), Fuchs et al. (2014). Other projects, in the federal land of North Rhine-Westphalia, are documented by Dohmann und Hördemann (2003) and Buer und Stepkes (2004). In these projects, CSO tanks were equipped with lamella separators of various sizes which were passed by the overflowing combined sewage. In most structures, inte-

gral (non-movable) upflow settlers were used. According to a number of the authors mentioned, lamella clarifier modules showed considerable accumulation of sludge and gross solids in combined sewage applications. This is a decisive operational disadvantage. Hand cleaning, e.g. by a firehose, is time-consuming or even dangerous. Some cleaning method or mechanism is thus desirable; moreover, the lamella or honeycomb spacing must not be too close, e.g. > 80 mm as recommended by the German guideline DWA-A 166 (2013) on CSO structures.

For cleaning of storm runoff in separate systems which may also be considerably polluted, lamella separation is used, too. Some suppliers offer ready-made concrete tanks with integral lamella separators which are operated as sedimentation tanks with a permanent water level. Moreover, there are some larger pilot projects, see Glas und Störr (2007) or Andritschke (2010). Numerical simulations on the flow distribution on upflow and cross-flow types were made e.g. by Schaffner, Morin und Steinhardt (2010), Schaffner, Pfeffermann et al. (2010), Steinhardt and Schaffner (2007), or Vasquez et al. (2010). In other countries, lamella separation is also used for different applications in urban drainage; see e.g. Daligault et al. (1999), Boogaard et al. (2010) or Ngu et al. 2012.

The DESSIN project partner UFT has gained own experience by testing a prototype in 2010 (non-published) and by some commercial units. The basic idea for separate systems is to have storage in the volume of the existing stormwater sewer, while treatment is done in a small but heavily charged lamella separator featuring a cleaning mechanism, see Weiss (2014).

### 1.3 Recent research project on upflow lamella settlers

In 2014, a research project was completed which was granted by the German federal land of North Rhine-Westphalia and where UFT took part (KIT 2015 a, KIT 2015 b). In this project, the use of upflow settlers was investigated first by model tests and later also in a testing container with real wastewater, a line of action which will be followed also in the present project DESSIN. Thus, the recent project is described a bit more in detail.

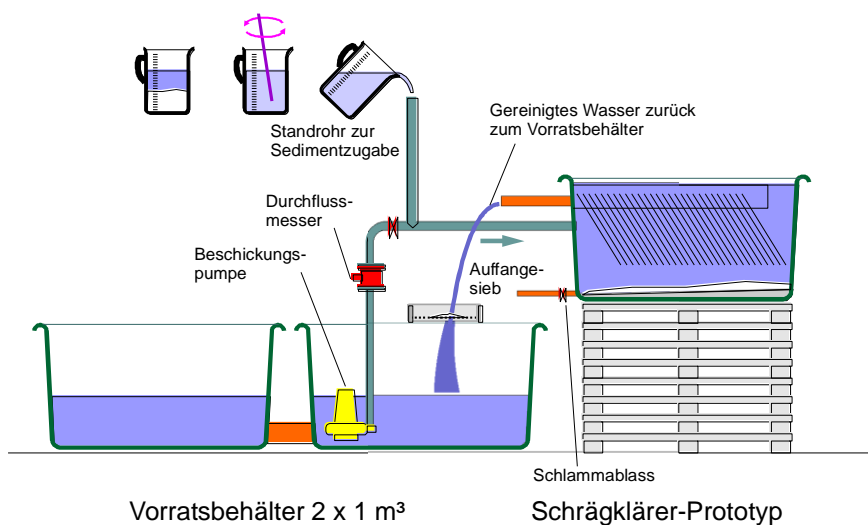

Figure 2: Model test rig of the past experiments on an upflow lamella separator (from KIT 2015b)

The experimental rig featured closed-loop water circulation which allowed also the addition of salt to the water in order to reduce the settling velocity of the model sediment (small polystyrene beads). Sediment is collected from the overflow and also after emptying of the tub by a fine-meshed fabric sieve. Efficiencies were computed by the sediment volume in Imhoff cones.

As a second project phase, prototype investigations were conducted. A mobile container was equipped with upflow lamella modules (KIT 2015b). It was operated by a feeding pump with combined sewage or even dry-weather sewage from the inflow of a treatment plant. Volume-proportional 1000 L samples were taken by peristaltic pumps at the inflow and at the overflow of the container. The collected settleable solids were separated in fine and coarse fractions. Final evaluation yielded event-mean efficiencies under steady-flow operation of the container.

An important issue was also the question of uniform flow distribution over the lamella modules, which was investigated both by numerical flow simulation and also by thorough velocity measurements in clear water.

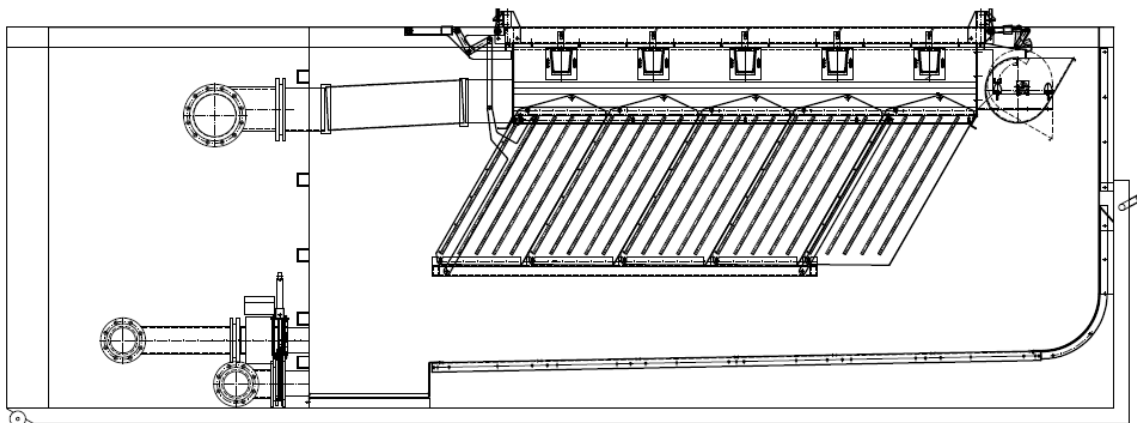

Figure 3: Section drawing of the upflow lamella container (KIT 2015 b)

The results revealed some essential insights:

- The model tests showed surprisingly low overall settling efficiencies for the well-rolling model sediment. It was found that this was caused by sliding down of particles which had already settled on the plates. They were re-mixed into the flow beneath the modules. Another effect was re-entrainment of settled grains by the flow without sliding down. Moreover, it was found that a considerable part of the efficiency was also caused by the tub in which the lamella modules were located, which is acting as a settling basin, too. It was not possible to separate sedimentation on the lamellae and in the tub. It was concluded that any theoretical, numerical or experimental approaches which only focused on the settling process on the lamellae are insufficient to describe the process. Such approaches suppose that a sediment grain is “settled” (and removed from the process) as soon as it has reached the lamella surface.



Figure 4: Upflow lamella container. Left: Top view with lamella modules and overflow system. Right: Container in place. In the foreground the feeding pump in the inlet flume of a treatment plant and one of the 1000 L samplers

- Another unexpected result was that the prototype tests with the container revealed removal efficiencies for fine settleable solids which were reasonably good and much higher than a prediction using the model efficiencies had yielded. This is due to the different behaviour of well-rolling model sediment and real settleable solids from sewage which e.g. may be “sticky” so that sliding down and remobilisation processes are different. Possibly spontaneous flocculation plays an additional role. More thorough investigations of detailed sediment properties could not be performed in the course of the project. It could be concluded that model tests may serve for general insights in some processes, but the idealized settling curves are not suitable for any prediction of prototype performance.

Both should be accounted for in the present project.

## 2 Cross-flow lamella settling: Some theoretical considerations

### 2.1 Basic sedimentation theory

There is a lot of theoretical work on lamella separators, such as e.g. Yao (1970) or Binder and Wiesmann (1983). Most of these papers investigate the process of settling of idealized particles in the flow field between the lamellae or honeycomb profiles by taking into account the profile geometry and/or the flow more in detail. In the following, merely some basics shall be illustrated since the evaluation methods of the model test results are based on these relations and parameters.

The best known and most simple steady-flow sedimentation theory is the one by Hazen of 1904 for a rectangular sedimentation basin, cited e.g. in Camp (1953). The settling efficiency  $\eta$  of an ideal sediment of given settling velocity  $v_s$  may be expressed by a concentration ratio

$$\eta = 1 - \frac{C_{over}}{C_{in}} \quad (1)$$

where  $C_{in}$  is the inflow concentration and  $C_{over}$  the overflow concentration, assumed both as constant. In this case, the efficiency may equally well be defined as a mass or a volume ratio of the sediment, such as

$$\eta = \frac{V_{sed}}{V_{sed} + V_{over}} \quad (2)$$

where  $V_{sed}$  is the settled and  $V_{over}$  the overflown volume of sediment particles. This definition is used in the present model tests.

In the Hazen theory, the efficiency is defined by

$$\eta = \min\left(1; \frac{v_s}{q_a}\right) \quad (3)$$

where  $q_a = Q/(B \cdot L)$  is the surface loading of the sedimentation basin of length  $L$  and width  $B$ . The sedimentation basin is assumed to be passed by a horizontal plug flow of uniform and constant parallel flow velocity  $v = Q / (B \cdot H)$ . All sediment particles having a settling velocity in exceedance of the surface load  $q_a$  (which has also the dimension of a velocity) will reach the basin floor and are settled in the basin while sediments with  $v_s < q_a$  will settle only to a certain percentage. The quotient  $v_s/q_a$  is also known as Hazen number. In a real sedimentation basin, however, this ideal Hazen settling efficiency will never be reached because of turbulence, backflow zones and non-ideal sediment properties.

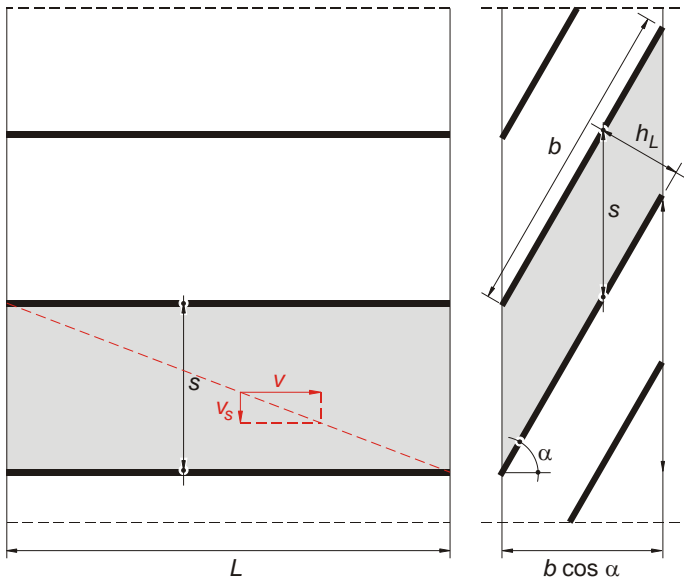

Figure 5: Definition sketch

It is possible to apply the Hazen theory also on a cross-flow lamella settler. We assume that the settler consists of parallel thin plates in an arrangement as of Figure 1, 3<sup>rd</sup> scheme. If we consider the space between two plates, the maximum settling path  $s$  for a single particle equals the vertical distance between the plates, which is given by  $s = h_L / \cos \alpha$  where  $h_L$  denotes the plate spacing perpendicular to the surfaces and  $\alpha$  the angle of inclination, see Figure 5. The plate thickness is neglected here. If the separator consists of  $n$  plates inclined by  $\alpha$  and having a length  $L$  and a width  $b$  perpendicular to the flow direction and if we assume that the sediment moves on a sedimentation trajectory in a vertical plane only, the passage through the lamella settler is equivalent as if the flow would have to pass in parallel  $n$  rectangular ducts or basins where each has a length  $L$ , a width of  $b \cdot \cos \alpha$  and a depth of  $s$ . The flow velocity is  $v = \frac{Q}{n \cdot s \cdot b \cos \alpha}$ . For any of these  $n$  hypothetical basins, the Hazen theory holds where  $q_A = \frac{Q}{n} \cdot \frac{1}{L \cdot b \cos \alpha}$ . We get then the expression

$$\eta = \min \left( 1; \frac{v_s}{\frac{Q}{n} \cdot \frac{1}{L \cdot b \cos \alpha}} \right) \quad (4)$$

The total projected area  $A_{proj,tot}$  of the  $n$  lamella settler plates is given by

$$A_{proj,tot} = n \cdot L \cdot b \cos \alpha \quad (5)$$

which yields again the standard Hazen formula Eq. (3) if only the surface loading is calculated using the total projected area, as  $q_A = Q/A_{proj,tot}$ .



Enhancements of this theory may account for the fact that there are triangular spaces at the upper and lower ends of the lamellae where the maximum settling path is less than  $s = h_L / \cos \alpha$ , as well as for other effects like the plate thickness. It is not necessary that these are elaborated further here.

Basically, the settling efficiency  $\eta$  is dependent on the dimensionless relation  $q_A/v_s$ , as it is in a standard sedimentation basin. For a given flow  $Q$  and settling velocity  $v_s$ , a small  $q_A/v_s$  requires a large total projected area of the lamella modules. This needs either a large volume of the lamella modules, or, a small lamella spacing  $h_L$ . Suppliers of lamella modules state a specific projected area in  $m^2/m^3$  of module volume. For practical application in storm runoff or combined sewage, however, some minimum spacing is desirable because of the danger of clogging by accumulated sludge or by gross solids.

## 2.2 Dimensional analysis

One standard tool in hydraulic model tests is to use dimensionless quantities as ratios of physical properties, in order to get less parameters and, moreover, to allow easy comparison between different model sizes and between model and prototype. There is a formal mathematical procedure to gain a set of dimensionless parameters from dimensional properties which can be found in any textbook on hydraulics, so it is not necessary to deduce it in detail. Anyhow, the results are as follows:

For a given geometry of the lamella settler, we consider the following set of dimensional properties which are independent:

$$V_{over} = f(V_{sed}, Q, A_{proj,tot}, h_L, v_s, L, B, H, g, \nu) \quad (6)$$

where  $h_L$  is the lamella spacing and  $L$ ,  $H$  and  $B$  the dimensions of the flume. The gravitational acceleration  $g$  and the kinematic viscosity  $\nu$  are added for physical completeness only (of course no one will probably conduct lamella settler tests on the moon in near future). It is possible to replace this relationship of 11 kinematic parameters (whose dimensions contain only two basic units, i.e. length (m) and time (s)) by regarding an equivalent set of  $11 - 2 = 9$  dimensionless quantities. The set of parameters may be modified by replacing some parameters by more advantageous combinations of them, but the number must not be reduced. One resulting set of variables could be as follows:

$$\frac{V_{sed}}{V_{sed} + V_{over}} = f\left(\frac{Q}{A_{proj,tot} \cdot v_s}, \frac{Q}{BH \sqrt{gH}}, \frac{L}{H}, \frac{B}{H}, \frac{A_{proj,tot}}{L \cdot B}, \frac{h_L}{H}, \frac{Q}{BH} \cdot \frac{h_L}{\nu}\right) \quad (7)$$

Next, it must be determined which of these parameters are essential to investigate. The terms parameterize *independent* effects, i.e. each of the terms on the right side is suspected to influence the left-side term even if all others were kept constant. Dimensional analysis, however, does not reveal whether the set of parameters is sufficient or whether there are redundancies or missing dependencies, nor does it show the kind of dependency, so this requires some argumentation:

- The leftmost term is (of course deliberately) the definition of the sedimentation efficiency, which is itself dimensionless. This is the target variable whose dependencies are to be investigated.
- The parameter  $Q/(A_{proj,tot} \cdot v_s) = q_A/v_s$  is already known e.g. from the Hazen sedimentation theory as dimensionless expression of flow, scaled with the settling surface. This is the main dependency parameter.
- $Q/(BH\sqrt{gH})$  is formally the Froude number of the main flow in the flume; it is varied with  $Q$  only since  $B$  and  $H$  are constant. It is not expected that this parameter gains separate influence additionally to  $q_A/v_s$  since the Froude number is rather small. This parameter may be neglected.
- We use always the same flume where the water depth  $H$  is only feebly dependent on the flow, so we can assume that  $L$ ,  $B$  and  $H$  are constant, as well as the dimensionless ratios  $L/H$  and  $B/H$ . For the evaluation of model tests, these parameters are neglected, too.
- The parameter  $A_{proj,tot}/(L \cdot B)$  is dependent on the number and type of modules inserted. It resembles the ratio of the total projected settler surface to the flume surface. We will see that this is important later.
- $h_L/H$  is a similar geometry parameter which can be used alternatively<sup>1</sup> to  $A_{proj,tot}/(L \cdot B)$ . This is a redundancy.
- Finally,  $Q/(BH) \cdot h_L/v$  is a Reynolds number of the flow in the parallel gaps between the lamellae. If  $h_L$  is noted, it is accounted for automatically. This parameter is a measure of turbulence in the lamella gaps. It would have some influence if e.g. model tests with very small lamella spacing and prototype tests with a large spacing should be compared, particularly at large flows where turbulence is decisive. The present model tests work with the same lamella spacing as the prototype, so it can be argued that this parameter may be removed from the list, too.

For the evaluation of the model tests, the following set of variables is used:

$$\eta = f\left(\frac{q_A}{v_s}, \frac{A_{proj,tot}}{L \cdot B}, Geometry\right) \quad (8)$$

Since in dimensional analysis, any parameter may formally be replaced by combinations of it with other parameters<sup>2</sup> unless the number of parameters is reduced, this is equivalent to:

$$\eta = f\left(\left(\frac{q_A}{v_s} \cdot \frac{A_{proj,tot}}{L \cdot B}\right), \frac{A_{proj,tot}}{L \cdot B}, Geometry\right) \quad (9)$$

<sup>1</sup> It can be shown that in a flume of given  $L$ ,  $B$ ,  $H$  where the either 1 or 2 lamellae modules have a length of  $\frac{1}{4} L$ , the projected area  $A_{proj,tot}$  is directly reciprocal to the lamella spacing,  $h_L$ , and the number of modules. Thus, both parameters are not independent and it is sufficient to regard one of them only.

<sup>2</sup> If the dependency of a property  $Y$  on two variables  $A$  and  $B$  is sought which both are suspected to have an *independent* influence on  $Y$ , it is alternatively possible to investigate the dependency on  $(A \cdot B)$  and still also on  $B$  alone. The functional relation with  $(A \cdot B)$  does not necessarily comprise both dependencies.

where the first parameter may also be calculated as  $\frac{q_A}{v_s} \cdot \frac{A_{proj,tot}}{L \cdot B} = \frac{Q}{L \cdot B \cdot v_s}$ , i.e. also a  $\frac{q_A}{v_s}$  value where  $q_A$  is calculated using the floor area of the flume,  $L \cdot B$ , rather than the total projected surface of the lamella settlers,  $A_{proj,tot}$ . We will use this set of parameters later.

“Geometry” allows to include also tests without lamellae or with “tail strips” or horizontal lamellae not included in the above dimensional analysis.

## 3 Model tests on cross-flow lamella separators

### 3.1 Experimental setup

The concept of the new experimental rig for the DESSIN model tests was based on an idea of how future structures for lamella-enhanced settling could look like. This means either that a CSO tank is equipped or retrofitted with lamella modules, or, that small lamella settler units (e.g. in ready-made concrete tanks) fed with pumps, such as proposed (for the separate system) by Weiss (2014), are used but fitted with cross-flow lamella modules. Thus, the experimental rig was designed with the following features:

- Small, easy-to-clean flume equipped with one or two removable cross-flow lamella modules. Tests are possible also without any modules for comparison. Simple design with longitudinal throughflow, featuring the intake at one end while the overflow is a weir on the opposite end. This design is much simpler than it would be for an upflow settler where a flume system above the modules is required (cf. again Weiss 2014).
- The flume resembles a small lamella treatment unit as a possible future prototype realization, e.g. a precast concrete tank of, say, 2 m internal width for easy road transport. The flow pattern in the model then is similar to the pattern in such a prototype. The experimental container which shall be used in further steps of the DESSIN project should also be designed keeping approximately to the model proportions.
- The proportions of the flume are similar to those of rectangular concrete detention basins; however we did not keep to the proportions width:depth = 2..4 required by the German technical rule DWA-A 166 (2013), with respect to the possible future prototype realisation as a compact precast concrete structure and also to the experimental container for later DESSIN project phases.
- Appurtenances for homogenous distribution of throughflow (e.g. a flow dispersion plate or a distribution manifold pipe)
- Tests with different lamella spacing and shapes are possible using exchangeable modules
- The general data of the lamella settlers, particularly spacing, total projected area and inclination angle, are kept close to the data of the past project (KIT 2015b) for the sake of comparison
- Similar setup as in the past project (use of existing pumps, MID flowmeter, and other devices)

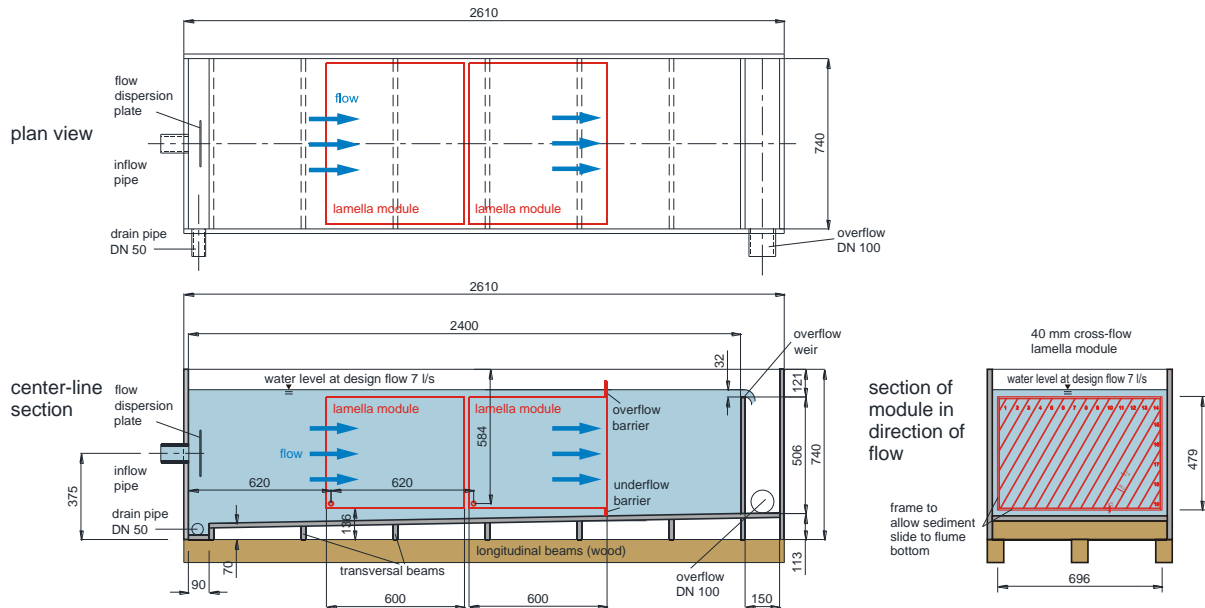

**Figure 6: Final design of the experimental flume with two cross-flow lamella modules**

The experimental flume is shown in Figure 6. It was constructed from waterproof-coated plywood sheets. Due to the limited budget, no glass walls were used. The flow phenomena were well observable from above since the lamella modules were made from clear methacrylate (Perspex) and could be made visible using dye.

The two removable cube-shaped lamella packages or modules had a length of 600 mm each. The first tests were made using 60° inclination angle and 80 mm spacing, later, additional plates were inserted to get a spacing of approximately 40 mm. One lamella module has a projected settling area of 2.22 m<sup>2</sup> at 40 mm lamella spacing. Using both modules, the total projected settling area is then 4.44 m<sup>2</sup>, equal to the past experiments. With 80 mm lamella spacing, the values are halved.

Additional tests were also made using horizontal plate settlers in order to investigate the effect of sliding down of the particles. Due to geometry, horizontal settler modules of the same spacing and the same overall volume have the double projected settling area than 60° cross-flow settlers.

Some “zero tests” use the flume only, with both lamella modules removed. These tests can be compared with results from literature for settling basins.

The flume has a width of approximately 75 cm and the same depth, allowing easy access and handling. The flume length is 2400 mm = four times the lamella module length, because the experimental rig should not get too large. In prototype size, it is desired to use a compact structure with minimum necessary space between the front and rear wall and the lamella packets. This is of course some contradiction to the desired homogenous flow distribution which would call for a long structure.

The design of the model could additionally be simulated numerically by other DESSIN partners to get an idea of the flow pattern inside and on the degree of inhomogeneity. Calibration of the simulation model by velocity measurements would be straightforward, but velocity measurements would require a very small sensor such as thermo-film or laser-Doppler anemometers in order not to disturb the flow, so due to our limited budget, no flow velocity measurements were made.

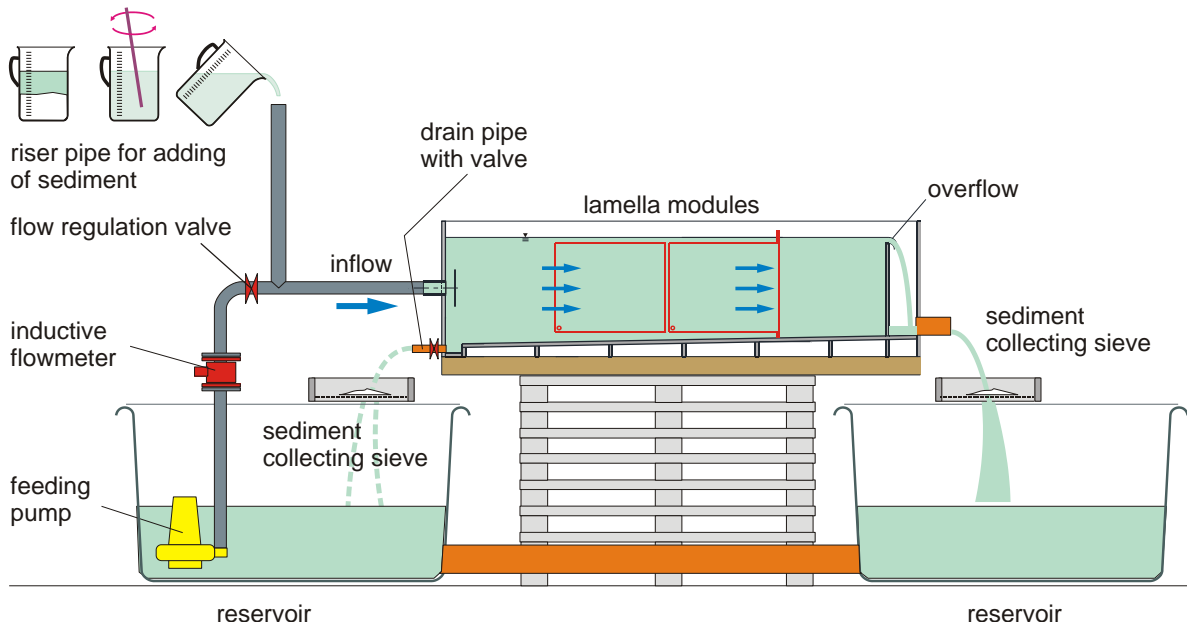

Figure 7: Schematic setup of the experiments

## 3.2 Experimental program

### 3.2.1 Qualitative tests of flow pattern

Before starting quantitative tests where settling efficiencies should be measured, the flow pattern through the test flume was observed by dye tests. Essential for the flow distribution is the inflow to the flume where the DN 75 inflow pipe ends bluntly in the wall. Without any further flow-dividing appurtenances, there is a strong free jet blowing straight through the tank. The momentum of this jet would cause a high-velocity longitudinal flow through the central part of the lamella modules, but low flow velocity or even backflow close to the flume bottom and walls. In order to avoid this undesired flow pattern, we used generally a T-shaped pipe manifold with four outflow orifices “blowing” backwards against the wall. A simple dispersion plate was found to be not sufficiently effective. Visually, the flow distribution was rather homogenous; we did not notice large backflow zones. Moreover, the lamella units acted as flow rectifiers. As mentioned, a record of the two-dimensional longitudinal flow profile was not possible due to the lack of a suitable local velocity measurement device.

The flume design should be simulated numerically (by the University of Essen as DESSIN partner) in order to verify the observed flow patterns in the model.

### **3.2.2 Model sediment**

For the sake of comparison, the same model sediment was used as in the past project. It is “non-popped” BASF Styropor P 423 which consists of polystyrene particles, including some tiny bubbles of a solvent. This material is usually used in packing industry to make Styrofoam blocks or packages by heating and “popping-up” in moulds. The non-heated material are nearly perfect spheres with a very uniform grain diameter of approximately 0.5 mm. It does not stick and is easily to recover from the flow by simple sieving with fine fabric. The settling velocity of the particles is approximately 0.4 mm and very steeply graded. All in all, the material is nearly ideal model sediment.

In the course of the mentioned past project, there had been thorough investigations of the distribution of settling velocity of this material in tap water (without addition of salt) as well as with different salt concentrations. In all tests, the water temperature and also the fluid density of (salt) water (the latter measured directly using a hydrometer) were noted down so that the settling velocity could be determined from the data of the past project.

The handling of the model sediment in the tests required some practice. Before adding it to the inflow, the sediment must be wetted and treated with some detergent to reduce surface tension and to improve the wettability. Used material could be re-used without drying. Tests revealed that there was no measurable influence on the settling velocity even if the material had been wet for several weeks, including with salt water.

### **3.2.3 Determination of steady-flow settling efficiency**

The schematic setup of the experiments can be seen from Figure 7. The tests were conducted as follows: After placing the lamella modules in the flume, it was filled up and the desired constant inflow was adjusted. The flow was controlled manually by the reading at the MID flowmeter; it kept reasonably constant (steady state). The sediment recovering sieve was placed under the overflow pipe in order to trap any escaped particles. Now, a portion of sediment (approximately 500 g of dry weight) was prepared by wetting and stirring, adding some drops of detergent. It was added at one instant into the inflow by the riser pipe and flushed by some litres of water taken from the flume. Then, the test was run generally during one hour<sup>3</sup> which proved as sufficient to allow all sediment to pass, i.e. either to settle down in the flume or to be entrained into the overflow.

It was necessary to take some time during the tests for simple observation of the flow and the settling process. The particles showed themselves as rather well visible flow tracers. Some observations were also recorded by a movie camera.

---

<sup>3</sup> In the former project, we had experienced also some re-entrainment of already settled particles by the flow, which made the measured settling efficiency dependent on the test duration. It is very difficult to avoid this effect, thus all tests were made with 1 h of standard time in order to yield comparable results.

The trapping sieve was a waterproof PVC frame lined with a fine fabric of mesh width of around 0.2 mm. In the centre, the frame featured a sinkhole which was closed with a rubber plug. In order to get the sediment out, the plug was removed and the sediment could be transferred into an Imhoff cone posed underneath. The sieve was rinsed with small amounts of water.

After one hour, the inflow was stopped. The trapped sediment in the overflow sieve was transferred carefully into one or two Imhoff cones, as described. Then, the empty and clean sieve was put under the drain pipe of the experimental flume. The flume was emptied including the sediments settled on the lamellae as well as in the structure. All surfaces were cleaned by careful flushing with a spray hose. Again, all sediments trapped in the sieve after this procedure were transferred to further 1-2 Imhoff cones.



Figure 8: Left: Overflow fabric sieve for recovery of model sediment (the round coarser sieves above acted as antispash protection only). Right: Imhoff cones for determination of sediment volume after 24 h of settling

After one day of settling, the “settled” and “overflown” sediment volume in the Imhoff cones was determined and noted down as  $V_{sed}$  and  $V_{over}$ , respectively. The steady-flow settling efficiency could then simply be determined as

$$\eta = \frac{V_{sed}}{V_{sed} + V_{over}} \quad (10)$$

We did not determine the total volume  $V_{tot}$  of the added sediment before flushing it into the experimental rig. Since all sediment could be recovered fairly well, it can be assumed safely that  $V_{tot} = V_{sed} + V_{over}$ , i.e. no sediment losses occurred.



### 3.2.4 Test runs

The test runs were distinguished by different settings:

- Geometry of lamellae:
  - a) 60° smooth plates: 40 mm or 80 mm lamella spacing, 1 or 2 modules
  - b) 60° smooth plates with a “tail strip” (which should prevent sediment from being entrained into the flow). Only tests with 2 modules and 40 mm lamella spacing.
  - c) Horizontal plates, 80 mm lamella spacing, without “tail strip”
- Discharge Q: varied in at least 6-7 steps, e.g. 2,3,4,5,6,7,8 L/s. In most cases, we started with a large flow which then was subsequently reduced. Any subsequent test then showed an improved settling efficiency. When e.g. 95 % - 98 % efficiency was reached, it was not necessary to continue with even smaller flows.
- We used always the same model sediment. To vary the settling velocity, a different fluid density was obtained by adding more or less salt. The maximum salt concentration<sup>4</sup> in the past tests was around 4 %, slightly more than sea water. To achieve this, around 100 kg of table salt are necessary for 2.5 m<sup>3</sup> of water volume in the experimental rig. Salt was added just like sediment and the process of dissolving was observed. Instead of measuring the salt concentration, the density of the salt solution was measured during any test using a hydrometer. The concentration changed gradually, by water losses and also by the flushing of sediment using sweet water.

All 157 test runs are compiled in Table 1.

---

<sup>4</sup> In the mentioned recent project, tests with large salt content caused particularly large data scatter. One reason might be that a higher fluid density will make the settling velocity distribution of the sediment less steep, i.e. broader-graded, which makes it more sensitive to tiny air bubbles attaching to the sediment particles due to possibly insufficient treatment with detergent. However, there may be also some other reasons not yet understood completely. Thus, in the present project we refrained from using fluid densities larger than 1.03 kg/m<sup>3</sup>.

**Table 1: Compilation of test runs**

Run No.	Flow Q in L/s	Temperature in °C	Density in kg/L	Settled sediment Volume in mL	Overflow sediment Volume in mL	Settling efficiency in %
<b>Without lamella modules</b>						
K130823_3	1,0	20,0	1,000	965	11	98,87
K130823_2	3,0	20,0	1,000	940	71	92,98
K130917_4	3,0	19,5	1,000	805	64	92,64
K130822_3	5,0	21,5	1,000	640	200	76,19
K130917_5	5,0	20,0	1,000	900	252	78,13
K130823_1	7,0	20,0	1,000	685	485	58,55
L140324_1	5,0	19,0	1,007	620	300	67,39
L140324_2	7,0	16,0	1,007	415	550	43,01
L140324_3	8,5	16,5	1,007	210	705	22,95
L140327_1	3,0	15,0	1,016	800	230	77,67
L140325_3	5,0	14,5	1,016	480	540	47,06
L140325_2	7,0	13,5	1,016	150	750	16,67
L140325_1	8,5	13,0	1,016	74	850	8,01
K130912_3	1,0	20,5	1,034	680	200	77,27
K130913_1	3,0	20,0	1,034	330	925	26,29
K130912_2	5,0	20,2	1,034	22	980	2,20
K130910_4	1,0	22,0	1,048	16	610	2,56
K130910_3	3,0	21,5	1,048	5	1100	0,45
K130911_1	3,0	20,0	1,048	330	1100	23,08
K130909_6	5,0	22,5	1,048	15	1600	0,93
K130910_2	5,0	21,5	1,048	32	900	3,43
K130912_1	5,0	20,0	1,048	7	1200	0,58
<b>Lamella spacing 80 mm, 1 module</b>						
K130823_4	1,0	20,0	1,000	1075	4	99,63
K130823_5	3,0	20,0	1,000	915	27	97,13
K130826_4	4,0	21,5	1,000	1005	48	95,44
K130826_1	5,0	19,5	1,000	840	130	86,60
K130826_3	6,0	20,5	1,000	850	255	76,92
K130826_2	7,0	20,0	1,000	680	372	64,64
K130911_4	1,0	21,0	1,048	550	405	57,59
K130911_2	2,0	20,5	1,048	460	390	54,12
K130911_3	3,0	20,5	1,048	710	650	52,21
K130910_5	5,0	22,5	1,048	800	625	56,14
<b>Lamella spacing 80 mm, 2 modules</b>						
K130821_4	1,0	22,0	1,000	800	5	99,38
K130821_3	2,0	21,0	1,000	825	7,5	99,10
K130821_2	3,0	21,0	1,000	815	13	98,43
K130821_1	4,0	21,0	1,000	850	34	96,15
K130822_2	5,0	21,0	1,000	670	71	90,42
K130821_5	6,0	22,5	1,000	800	153	83,95
K130822_6	7,0	23,0	1,000	775	230	77,11
K130822_1	8,0	21,0	1,000	540	400	57,45
K130828_3	1,0	19,5	1,014	905	10	98,91
K130828_2	3,0	18,5	1,014	940	98	90,56
K130828_4	5,0	20,0	1,014	680	265	71,96
K130827_1	6,0	20,0	1,014	850	170	83,33
K130827_2	6,0	20,5	1,014	930	190	83,04
K130828_1	6,0	20,0	1,014	840	185	81,95
K130903_2	6,0	21,5	1,014	490	730	40,16
K130828_5	8,0	21,0	1,014	695	650	51,67
K130903_1	8,0	21,0	1,014	290	1000	22,48
K130904_4	1,0	21,0	1,026	1040	20,5	98,07
K130904_2	3,0	21,0	1,026	860	330	72,27
K130905_1	4,0	21,5	1,026	580	515	52,97
K130904_1	5,0	21,0	1,026	670	1020	39,64
K130904_5	6,0	21,0	1,026	225	495	31,25
K130904_3	8,0	21,0	1,026	103	910	10,17
K130905_2	1,0	21,5	1,038	890	545	62,02
K130905_4	2,0	23,0	1,038	640	1200	34,78
K130906_1	3,0	22,0	1,038	415	240	63,36
K130905_6	4,0	24,5	1,038	320	575	35,75
K130905_5	6,0	24,0	1,038	260	820	24,07
K130905_3	7,0	22,0	1,038	61	225	21,33
K130909_1	1,0	22,0	1,048	1950	300	86,67
K130909_2	3,0	22,5	1,048	1100	600	64,71
K130909_4	4,0	22,5	1,048	450	590	43,27
K130906_2	5,0	22,0	1,048	600	220	73,17
K130909_5	5,0	22,5	1,048	280	270	50,91
K130910_1	5,0	21,5	1,048	650	450	59,09
K130909_3	7,0	23,0	1,048	6	160	3,61
<b>Lamella spacing 40 mm, 1 module</b>						
K130917_1	3,0	18,5	1,000	840	13	98,48
K130917_2	5,0	19,0	1,000	750	110	87,21
L140312_3	3,0	16,4	1,000	1075	16	98,53
L140312_4	5,0	17,1	1,000	1000	110	90,09
L140312_1	7,0	15,7	1,000	900	180	83,33
L140313_1	7,0	17,7	1,000	930	185	83,41
L140312_2	8,5	17,2	1,000	600	450	57,14
L140313_3	8,5	17,8	1,000	575	420	57,79
L140318_1	5,0	16,0	1,000	1025	150	87,23
L140318_2	6,0	16,5	1,000	750	175	81,08
L140318_3	7,0	17,0	1,000	640	410	60,95
L140318_4	8,5	17,5	1,000	690	590	53,91
L140321_1	5,0	17,7	1,007	800	150	84,21
L140321_3	8,5	18,5	1,007	350	560	38,46
L140327_5	3,0	17,2	1,016	1000	64	93,98
L140327_4	5,0	16,6	1,016	700	290	70,71
L140327_3	7,0	16,0	1,016	320	705	31,22
L140327_2	8,5	15,5	1,016	200	700	22,22
K130919_6	3,0	20,0	1,026	520	310	62,65
K130919_4	5,0	19,5	1,026	305	260	53,98
K130919_5	7,0	19,5	1,026	250	650	27,78
K130913_3	3,0	20,0	1,028	575	295	66,09
K130913_2	5,0	19,5	1,028	320	520	38,10
K130913_4	7,0	20,5	1,028	420	545	43,52
K130918_3	3,0	19,0	1,014	745	102	87,96
K130918_1	5,0	18,5	1,014	600	400	60,00
K130918_2	7,0	18,5	1,014	360	750	32,43
K130911_5	5,0	21,5	1,048	605	510	54,26
<b>Lamella spacing 40 mm, 2 modules</b>						
K130916_4	3,0	19,0	1,000	940	26	97,31
K130916_3	5,0	18,5	1,000	1010	33	96,84
K130916_5	7,0	19,0	1,000	775	285	73,11
L140314_1	3,0	16,8	1,000	1000	9	99,11
L140311_1	5,0	12,3	1,000	660	90	88,00
L140311_2	5,0	14,0	1,000	700	80	89,74
L140311_3	5,0	15,5	1,000	1020	62	94,27
L140314_2	7,0	17,2	1,000	650	340	65,66
L140312_2	7,5	15,5	1,000	690	375	64,79
L140314_3	8,5	18,0	1,000	480	475	50,26
R140715_1	8,3	18,0	1,000	490	290	62,82
R140716_1	6,9	20,0	1,000	500	265	65,36
R140716_2	5,0	20,0	1,000	724	43	94,39
L140319_1	3,0	17,4	1,007	1150	32	97,29
L140319_2	3,0	17,9	1,007	1245	16	98,73
L140320_1	5,0	17,3	1,007	850	190	81,73
L140320_2	7,0	17,8	1,007	600	400	60,00
L140320_3	8,5	18,4	1,007	500	500	50,00
K130918_6	3,0	19,5	1,014	780	56	93,30
K130918_4	5,0	19,5	1,014	710	260	73,20
K130918_5	7,0	19,5	1,014	450	495	47,62
L140328_3	5,0	17,7	1,016	770	220	77,78
L140328_2	7,0	17,2	1,016	340	530	39,08
L140328_1	8,5	16,8	1,016	340	750	31,19
K130919_3	3,0	19,5	1,026	805	265	75,23
K130919_1	5,0	19,0	1,026	420	655	39,07
K130919_2	7,0	19,0	1,026	300	805	27,15
K130916_1	3,0	18,0	1,028	705	130	84,43
K130913_5	5,0	20,5	1,028	375	605	38,27
K130916_2	7,0	19,0	1,028	340	795	29,96
<b>With "tail strip", Lamella spacing 40 mm, 2 modules</b>						
R140722_1	8,3	18,5	1,000	465	310	60,00
R140722_2	7,0	19,6	1,000	553	235	70,18
R140723_1	6,0	20,8	1,000	704	80	89,80
R140723_2	4,9	21,4	1,000	725	50	93,55
R140723_3	4,0	22,2	1,000	760	23	97,06
R140723_4	3,0	22,8	1,000	810	4	99,51
R140724_1	5,0	21,8	1,003	755	34	95,69
R140724_2	4,0	22,4	1,003	770	37	95,42
R140724_3	7,0	22,6	1,003	570	215	72,61
R140725_1	3,0	22,1	1,003	761	18	97,69
R140725_2	6,0	22,4	1,003	672	139	82,86
R140725_3	8,3	23,0	1,003	400	371	51,88
R140728_1	5,0	22,5	1,008	700	71	90,79
R140728_2	5,0	22,5	1,008	1135	74	93,88
R140729_1	7,0	23,1	1,007	700	220	76,09
R140729_3	3,0	23,8	1,007	825	8	99,04
R140730_1	8,0	23,4	1,007	434	570	43,23
R140730_2	6,0	23,7	1,007	930	136	87,24
R140730_3	4,0	24,2	1,007	1210	17	98,61
R140731_1	7,0	23,1	1,011	636	365	63,54
R140731_2	5,0	23,2	1,011	908	92	90,80
R140731_3	3,0	23,4	1,011	1058	8	99,25
R140801_1	8,3	22,5	1,010	300	738	28,90
R140801_2	6,0	23,0	1,010	760	205	78,76
R140801_3	4,0	23,1	1,010	920	30	96,84
R140804_1	7,0	22,2	1,014	512	403	55,96
R140804_2	5,0	22,5	1,014	803	165	82,95
R140804_3	3,0	22,9	1,013	987	43	95,83
R140804_4	4,0	23,3	1,013	905	14	98,48
R140805_1	8,2	22,5	1,013	293	751	28,07
R140805_2	6,0	22,6	1,013	724	286	71,68

### 4.1 Steady-flow efficiency vs. flow

The result of any test is primarily the steady-flow separation efficiency  $\eta$  in %, corresponding to the given flow  $Q$  in L/s and the specific test settings (particularly the number and spacing of modules and the fluid density). Figure 9 shows these raw results for all tests with smooth 60° lamellae (tests with “tail strip” as well as with horizontal plates or without lamellae are not included). We can see at any series with the same shape and colour of dots that generally the efficiency decreases with increasing flow, just as expected also from theory. Anyhow, a strong influence of the remaining parameters is visible.

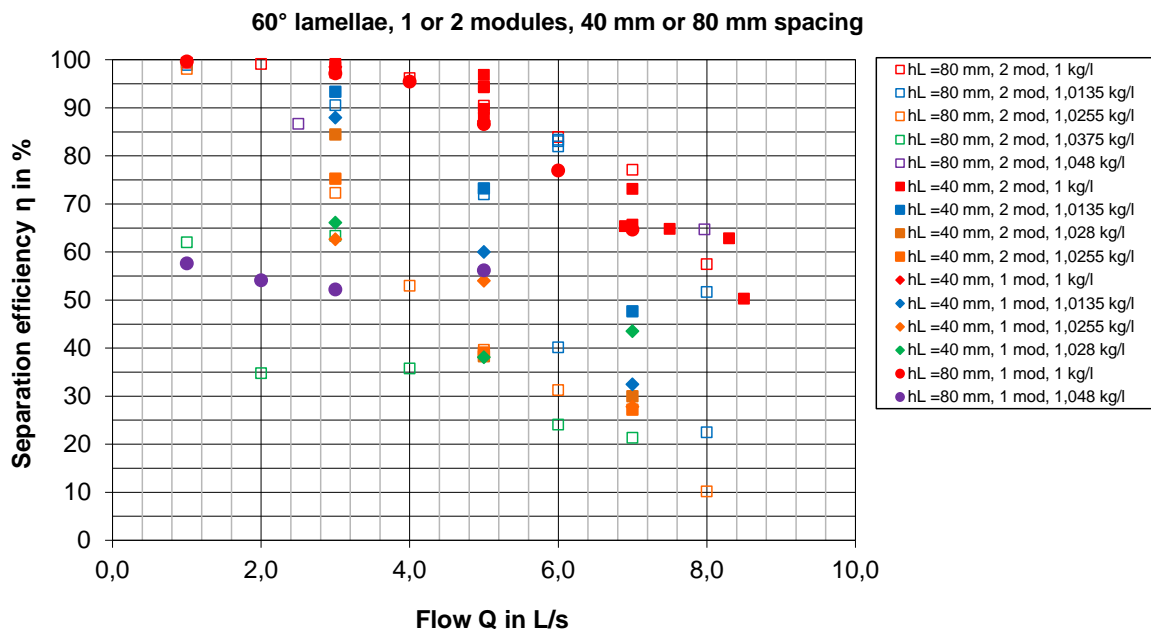

Figure 9: Direct plot of steady-flow separation efficiency vs. flow

### 4.2 Dimensionless plots

In order to investigate the influence of the test parameters individually, it is necessary to draw dimensionless plots. From dimensional analysis, see Chapter 2.2, it is already known that the dimensionless parameter  $q_A/v_s$  is the most essential one. A constant value of this property means that e.g. twice the flow at twice the settling area will probably yield the same efficiency and, moreover, that a sediment with e.g. twice the settling velocity will perform equally if the double flow is assumed over the same settling area, yielding double surface load. In the first instance, *we assume that sed-*

imentation will take place on the lamellae surfaces exclusively, which means that we restrict on this parameter. Later, we will see that this first-order assumption cannot be sustained.

Consequently, any deviations from an unique curve  $\eta = f(q_A/v_s)$  will be due to secondary effects since the main effects of different settling surfaces and of settling velocities are already accounted for. Formally, these secondary effects may be parameterized by the remaining dependencies from the list of variables from Chapter 2.2.

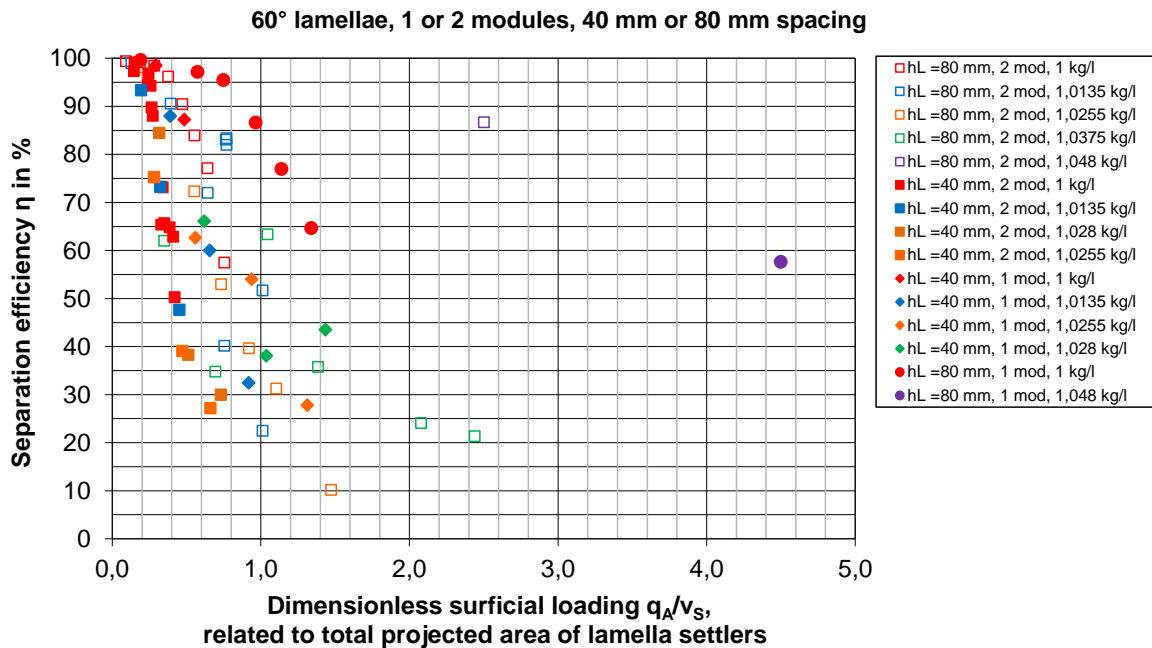

Figure 10: Dimensionless plot of settling efficiency

Figure 10 shows the same data as Figure 9 in dimensionless form. We see that there is by no way any unique curve, as expected. In the following, we will try to separate the secondary effects.

First, tests belonging to the same number of modules and lamella spacing are compared. Figure 11 shows this for two modules at 80 mm spacing. It can be seen that the tests with particularly high salt content (= density) show rather high efficiencies. It was found that this was due to floating of many particles. In the following, these tests were excluded. If they are removed, the resulting cluster of data points shows an approximately similar shape without “outliers”, anyhow with a large scatter, particularly again at tests with high fluid density (green squares). For the tests with 40 mm spacing, less scatter is observed and we can see a more or less unique curve. This shows that the settling velocity is balanced by the surface loading, i.e. the dimensionless approach is basically correct – at least as long as only tests with the same settling surface are considered. Figure 13 shows that this holds also for the comparison of tests with one 40 mm module and two 80 mm modules,

which have approximately the same total projected settling area (even if there is considerable scatter).

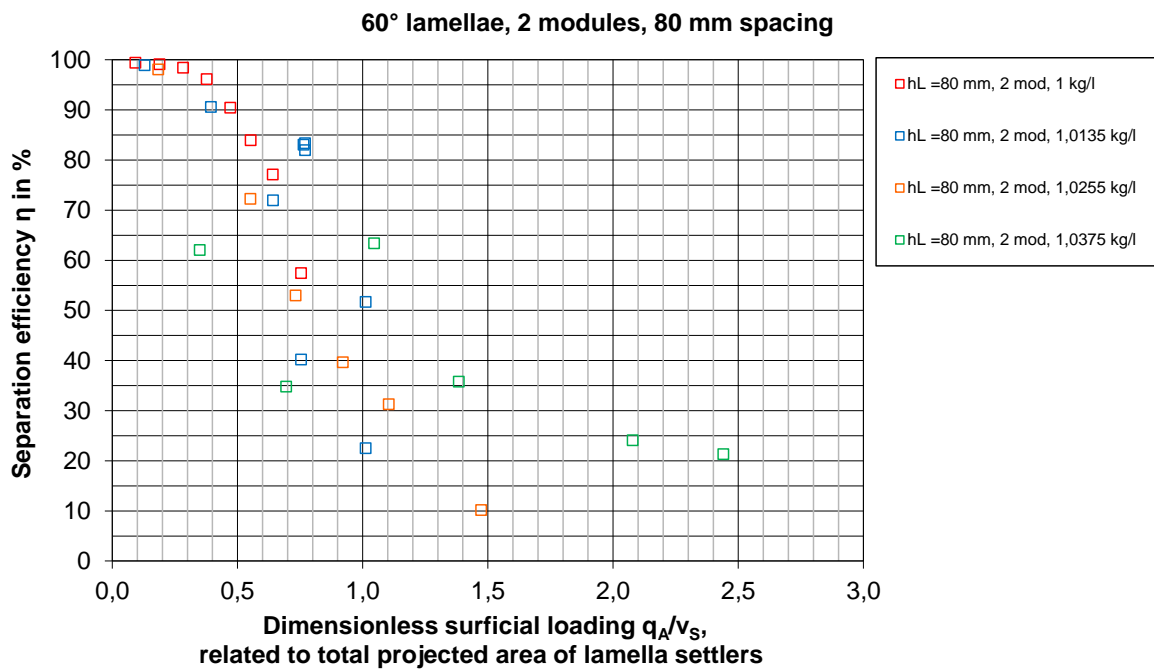
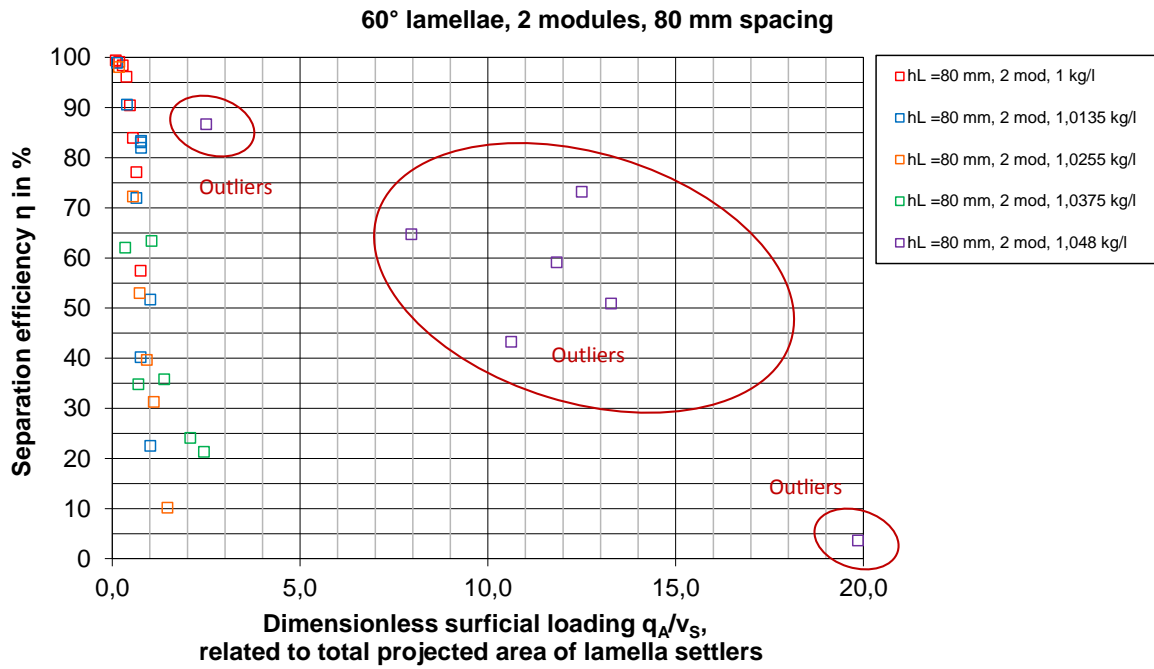

Figure 11: Results for 2 modules and 80 mm spacing. Top: The tests with particularly high density show numerous “outliers” with overestimated efficiency. Below: Same diagram, but with outliers removed and enlarged abscissa scale.

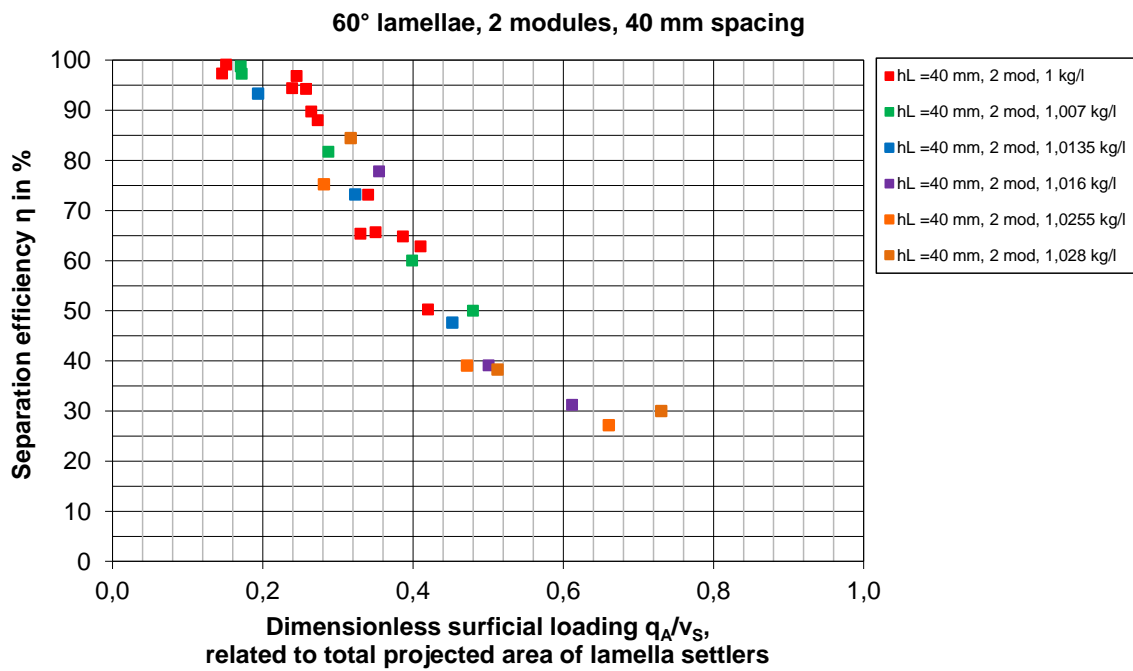

Figure 12: Results for 2 modules and 40 mm lamella spacing. Here, a more or less unique curve can be seen.

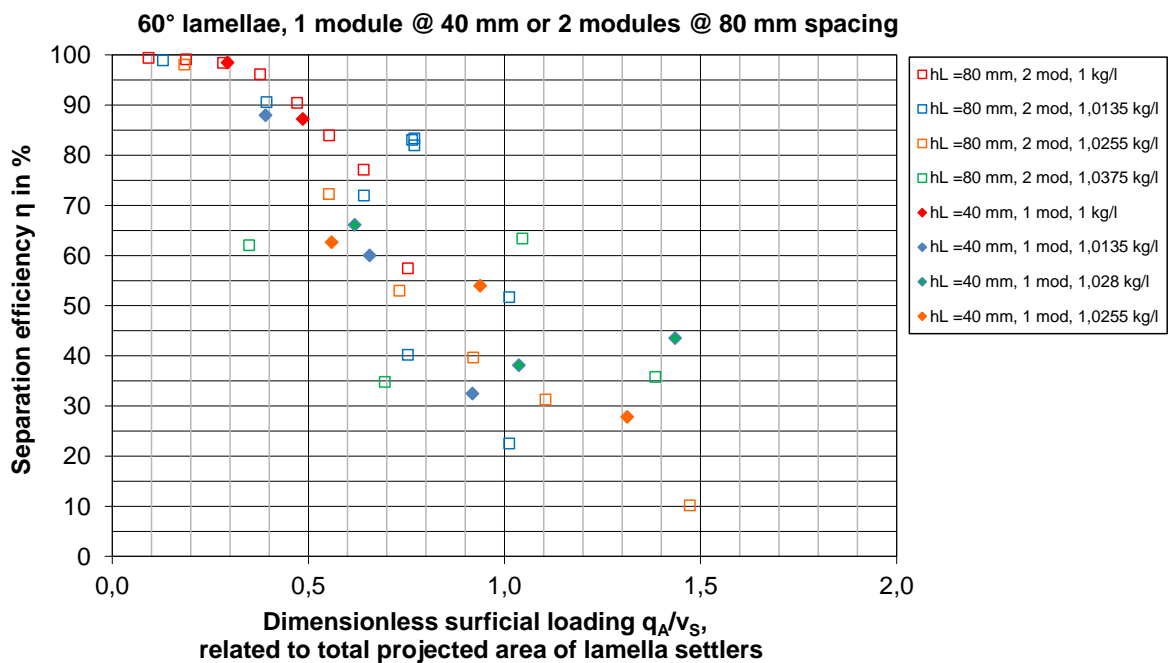

Figure 13: Comparison of results for 1 module with 40 mm and 2 modules with 80 mm lamella spacing (approximately equal projected lamella surface). The cluster is scattered, but it shows also a rather unique relationship.

Next, we have to investigate the relation of tests with different settling surfaces. Theoretically, the data clusters  $\eta = f(q_A/v_s)$  should coincide. However, as shown in Figure 14, this is obviously not the case. Instead, two distinct clusters can be seen for the tests with 80 mm and 40 mm lamella spacing.

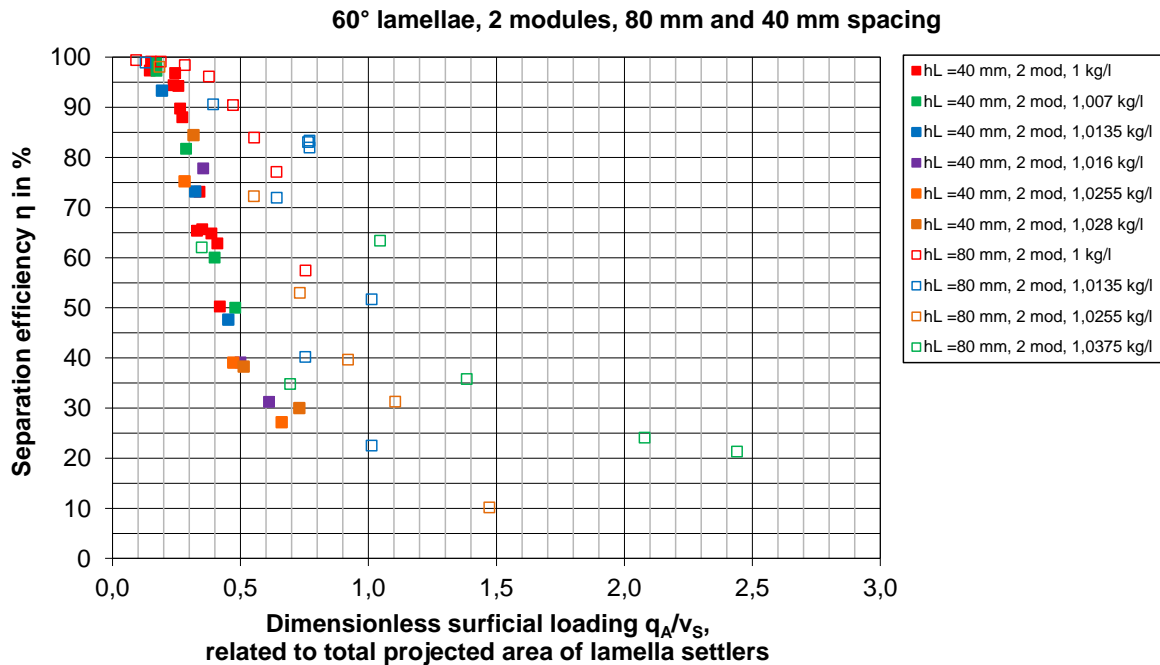

Figure 14: Comparison of results for 2 modules and 80 mm and 40 mm lamella spacing. Two distinct different patterns can be distinguished here.

But how can this be explained? It is not a question of a different surface load because it had already been shown that this effect is accounted for by scaling with the settling velocity.

The clue lies in the fact that *the tank in which the lamellae are inserted has itself also some sedimentation effect*, which can be seen directly from the tests without lamella modules. Formally, this could be assigned to the parameter  $\frac{A_{proj,tot}}{L \cdot B}$  from Chapter 2.2 which shows indeed different yet constant values for both sets of test runs (we get  $\frac{A_{proj,tot}}{L \cdot B} = \frac{4.44 \text{ m}^2}{2.4 \text{ m} \cdot 0.74 \text{ m}} = 2.5$  for 40 mm and 1.25 for 80 mm modules) since the settling area  $L \cdot B$  of the tank is not modified between the different sets of tests in Figure 14. For 80 mm modules with a smaller projected surface, the tank has some more influence than for 40 mm modules, and since all sedimentation effect is assigned to the lamella surface only, the efficiency is apparently “better” for the 80 mm modules and “worse” for  $h_L = 40$  mm for the same value of  $q_A/v_s$ .

Obviously, the efficiency is formally dependent<sup>5</sup> on  $q_A/v_s$  and also on  $\frac{A_{proj,tot}}{L \cdot B}$ . In order to get an idea which part of the measured effect is due to the tank and which due to the lamella modules, we can assume next that *settling takes place in the flume only*, i.e. in a settling basin with  $L \cdot B$  as plan view area. The abscissa then may be also a dimensionless  $q_{A,tank}/v_s$  value, but with  $q_{A,tank} = Q / (B \cdot L)$  as the surface load related to the tank rather than to the lamellae. In this context, also the results of some tests without modules can be drawn in. The abscissa parameter may also be written as

$$\frac{Q}{B \cdot L \cdot v_s} = \frac{Q}{A_{proj,tot} \cdot v_s} \cdot \frac{A_{proj,tot}}{L \cdot B} = \frac{q_A}{v_s} \cdot \frac{A_{proj,tot}}{L \cdot B} \quad (11)$$

i.e. we replace formally the abscissa parameter  $q_A/v_s$  by the product of both parameters mentioned.

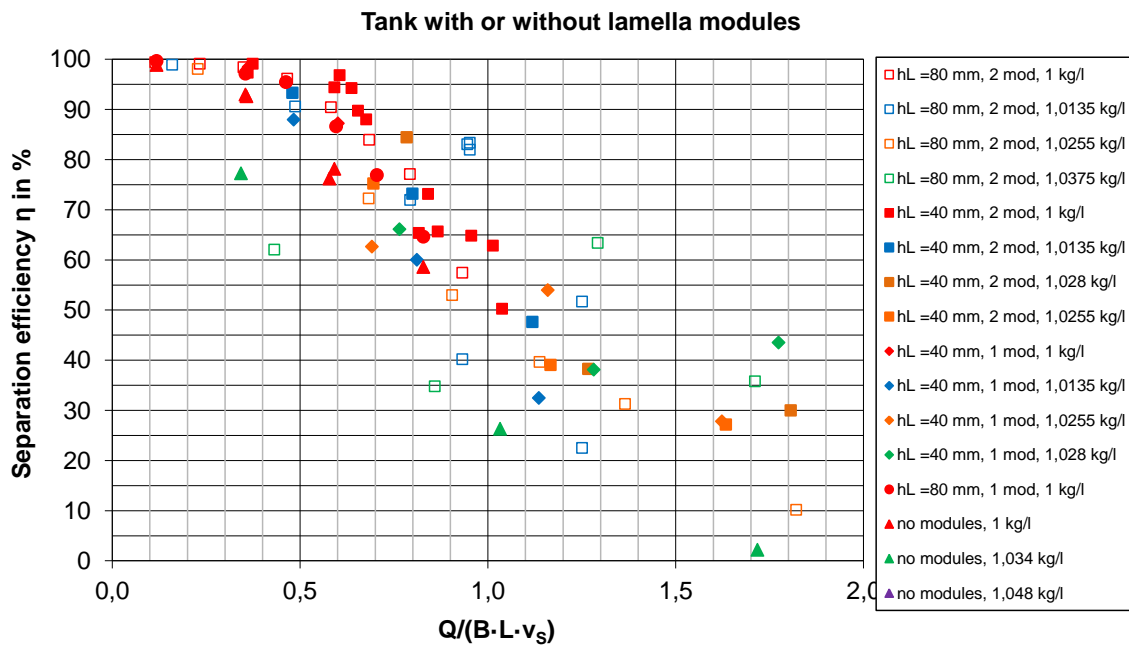

Figure 15: Using the different abscissa parameter, the test results of all configurations show nearly no significant separate patterns.

Figure 15 yields a somewhat surprising result: The data of all tests, including those without lamellae, group themselves in nearly the same manner. Since the scatter is large, it is even difficult to see whether any test series with lamella settlers show an improved sedimentation performance than the tank without settlers. There is at least some improvement, as can be seen from Figure 16 where only tests with a fluid density of 1 kg/l are shown. Here, the clusters show an enlarged efficiency

<sup>5</sup> From the parameter list of dimensional analysis in Chapter 2.2, one could formally also suspect that the mentioned effect might be a reason of another parameter, e.g. the Reynolds number,  $\frac{Q}{BH} \cdot \frac{h_L}{v}$ . If this would really cause this rather pronounced effect, however, we could also see in Figure 13 separate data clusters. Thus it is more probable that the effect is due to settling in the flume rather than due to viscosity.



with larger lamella projection area, i.e. tests with two 40 mm-modules outperform the 80 mm tests and these again the tests without lamella settlers. Anyhow, the effect is much smaller than expected.

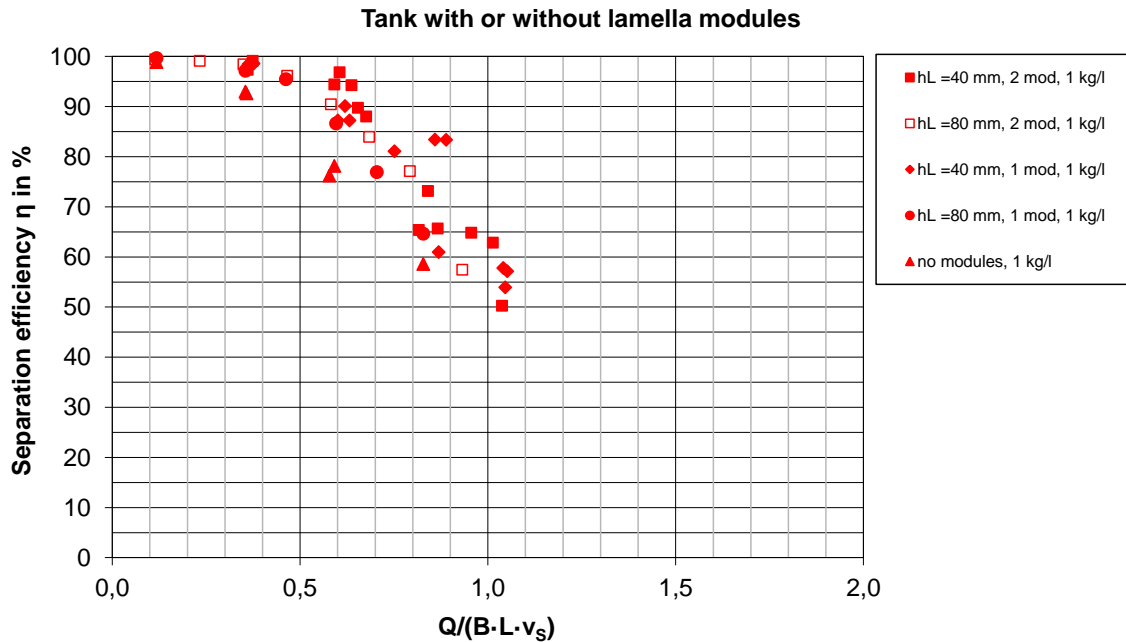

Figure 16: Same as Figure 15, but only with tests with density 1 kg/L.

To quantify the effect of increased settling performance due to the lamella surface, the data scatter must be removed somehow. In the following, we try to define average performance curves for any settler geometry (no, 1 or 2 lamella modules with  $h_L = 40$  mm or 80 mm). As a mathematical curve which shows  $y = 1.0 = 100$  % efficiency at the abscissa value  $x = Q/(B \cdot L \cdot v_s) = 0$  and which also has a  $y = 0$  asymptote for  $x$  approaching infinity, the following synthetic one-parameter graph can be used:

$$\eta = \frac{1}{\left(C \cdot \frac{Q}{B \cdot L \cdot v_s}\right)^3 + 1} \quad (12)$$

Using a minimum-least-square method in  $x$  direction (not shown here for brevity), the only parameter  $C$  can be fitted to any set of data points and the behavior of  $C$  can be investigated. Figure 17 shows that this curve follows the general trend of the data very well. This was also confirmed for other settler geometries (Figure 18).

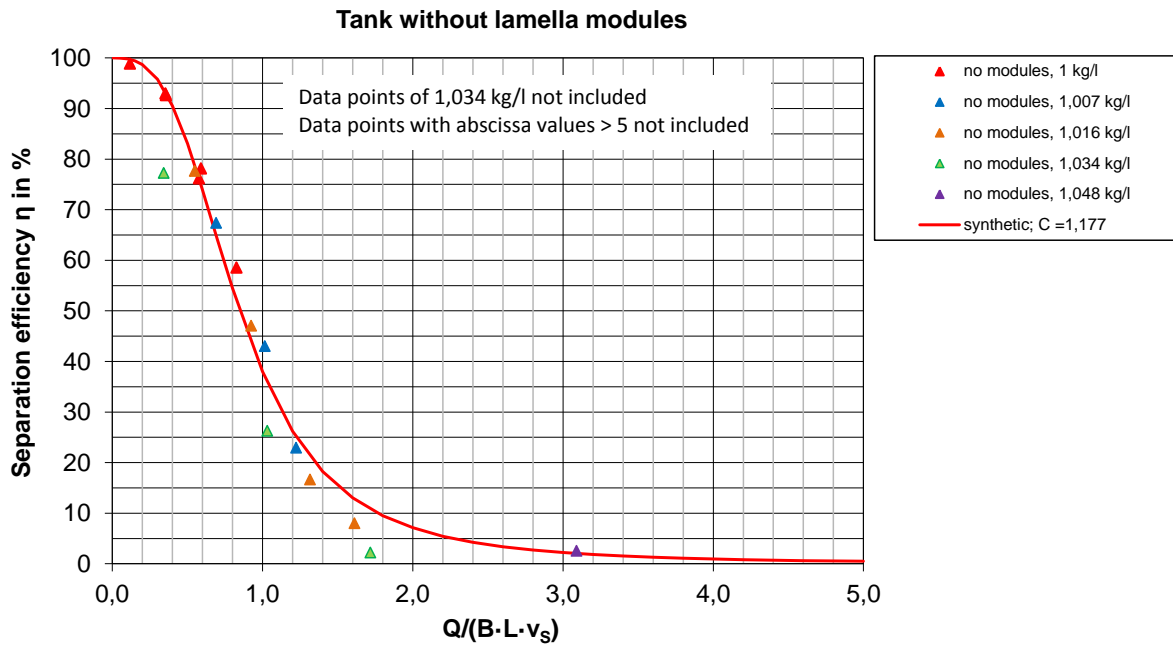

Figure 17: Approximation of data points by a single curve

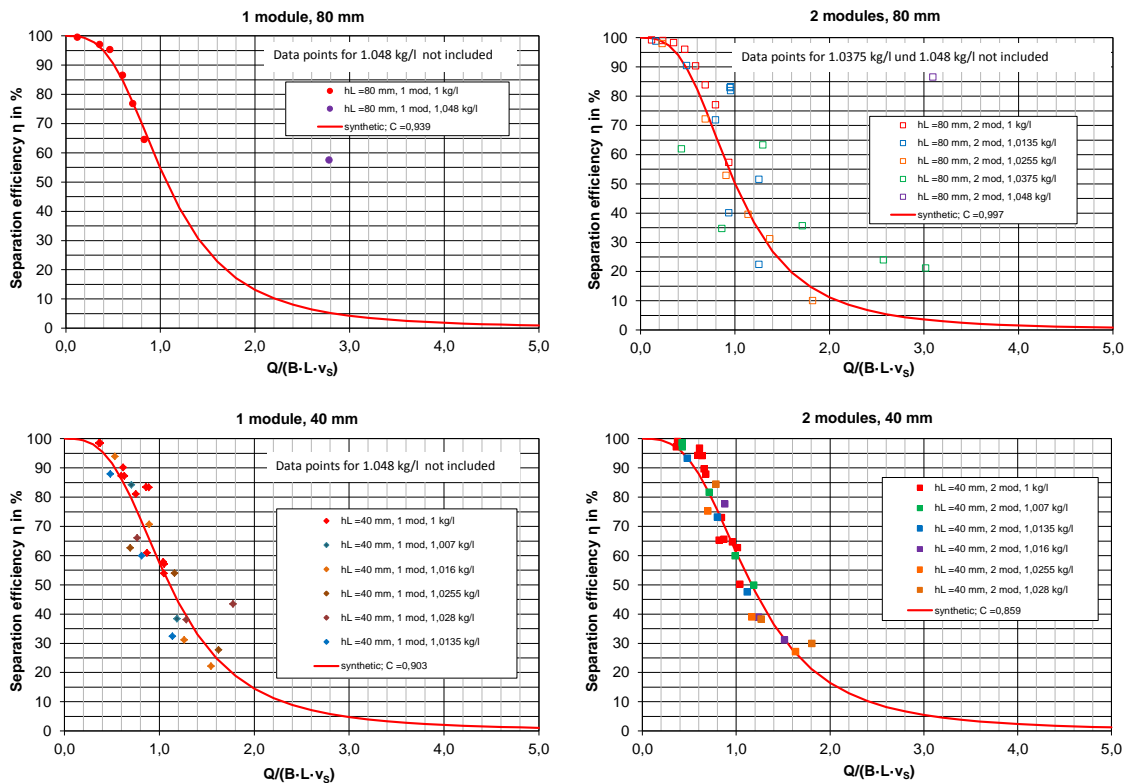

Figure 18: Same as Figure 17, but for other settler geometries

The parameter C describes the effective settling area of the combination tank plus inserted lamella settler modules as follows: For the tests without lamella modules, the effective settling area is  $B \cdot L = 0.74 \text{ m} \cdot 2.4 \text{ m} = 1.776 \text{ m}^2$ . We got the value  $C = C_0 = 1.177$  in this case. Setting up the same equation including lamella settler modules, we get a smaller value C. The inverse ratio  $C_0/C$  may be interpreted as an *apparent increase in settling surface* since  $1/C$  is linear with  $B \cdot L$  in the above formula. It is shown in Table 2 and Figure 19 in dependence on the ratio  $A_{\text{proj,tot}}/(L \cdot B)$  of projected lamella surfaces to flume surface.

Table 2: Apparent increase in settling surface if lamella settlers are installed

	Without modules	1 module $h_L = 80 \text{ mm}$	2 modules $h_L = 80 \text{ mm}$	1 module $h_L = 40 \text{ mm}$	2 modules $h_L = 40 \text{ mm}$
Total area of flume $L \cdot B$ in $\text{m}^2$	1.78	1.78	1.78	1.78	1.78
Projected area of lamellae $A_{\text{proj,tot}}$ in $\text{m}^2$	0.00	1.10	2.20	2.20	4.40
$A_{\text{proj,tot}} / (L \cdot B)$	<b>0.00</b>	<b>0.62</b>	<b>1.24</b>	<b>1.24</b>	<b>2.47</b>
C value	1.177	0.939	0.997	0.903	0.859
$C_0/C$	1.000	1.254	1.181	1.303	1.370
Apparent increase in settling area in %	<b>0.0</b>	<b>25.4</b>	<b>18.1</b>	<b>30.3</b>	<b>37.0</b>

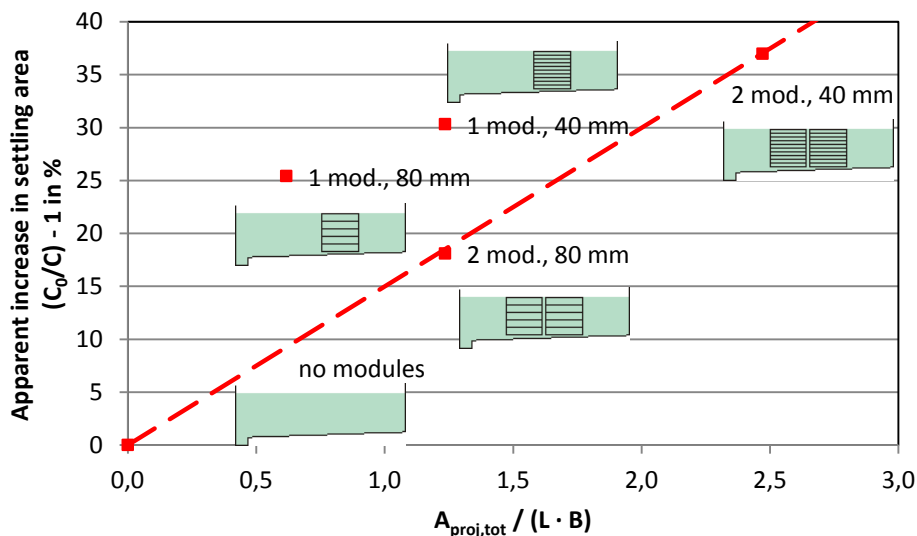

Figure 19: Apparent increase in settling area vs. ratio of lamella and flume surface

From Figure 19, it can be seen that the apparent increase in settling surface is much smaller than the increase in actual built-in total projected area of the lamella settlers. With other words: E.g. doubling the settling area of a sedimentation basin using cross-flow lamella modules will be less effective than using a larger sedimentation basin having double plan-view surface  $L \cdot B$ . Anyhow, we get an improved performance by the fact that it is easy to add large projected surfaces using lamel-

la separators with narrow gaps (small  $h_l$ ), but the effect is not proportional to the installed settling area.

Moreover, it can be noted from Figure 19 that the apparent increase of the settling surface is nearly linear to  $A_{proj}$  while the overall geometry is similar, i.e. two modules where only the plate spacing is different so that the overall flow pattern remains the same. The tests using only one module do not follow this linear relationship.

It should be noted that the additional installed settling surface was comparatively small in the model tests. This is due to the fact that we kept to 40 mm and 80 mm lamellae, i.e. prototype spacing, while the flume is much smaller than a real stormwater detention tank. 80 mm lamellae with 60° inclination angle have a specific projected area of around 6.2 m<sup>2</sup>/m<sup>3</sup> of volume. If, for example a detention basin of L:B:H = 20.0 : 4.44 : 2.0 m and V = 178 m<sup>3</sup> is equipped to half of its volume with 80 mm lamellae, we get a total projected settling area of 551.8 m<sup>2</sup> + ½ · 20 · 4.44 = 596.2 m<sup>2</sup>. This is an increase in 571 % over the plan-view area of 20 · 4.44 = 88.8 m<sup>2</sup> in the tank without modules. The model tests worked with an increase of max. (4.40 + ½ · 1.78) / 1.78 = 297 %, which is still large, but not quite as much. Even if the model test results are somewhat pessimistic, for a real stormwater tank with lamellae a good overall efficiency can be expected due to the very large settling surface.

What is the reason for this rather unexpected behavior? In KIT (2015b), upflow lamella separators were investigated where a quite similar phenomenon was observed; the sedimentation efficiency was much less than expected due to the active projected settling surface. It had been found out that this was probably due to rolling down of already settled sediments which mixed again into the inflow rather effectively. This effect is even more pronounced by the well-rolling grains used as model sediment.

The cross-flow lamella separator was used in the present project with the intention to avoid this non-desired effect. Sediments should slide down in sideward direction in order not to re-mix into the longitudinal main flow. The Perspex modules allowed visual yet qualitative observation of this effect and gave an interesting result: Single particles did not slide down more or less perpendicular to the direction of flow, as assumed, even on the rather steep 60° lamellae. Instead, many particles just stayed in contact with the surface. A large number of these grains was picked up or loosened by the flow, losing contact with the settler plate surface. Others did not get in contact with the settler plate surface when settling. But rather than just sliding down and following gravity, as expected, these particles typically followed a skew and irregular path, dependent on the flow, with a merely small downward component and a larger longitudinal component in direction of flow. Thus, they reach the trailing edge of the lamella plates and are again re-mixed into the flow. In fact, this is a similar effect as at the upflow lamella separator. However, it was not possible to observe this essential phenomenon in a more thorough and detailed quantitative way.

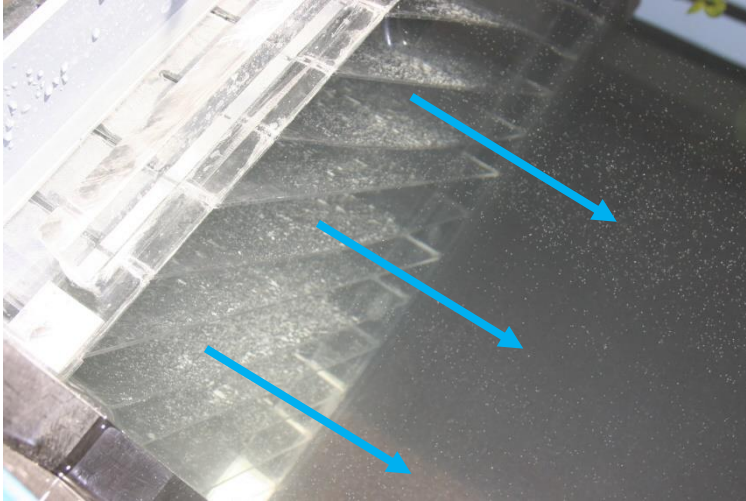

**Figure 20:** The trailing edge of the second lamella module during a test. A lot of sediment has settled on the inclined surfaces. A considerable number of grains are transported by the flow over the edge.

One idea to describe the observed effects would be formulating a phenomenological model which describes a) the process of settling of a certain percentage of the suspended sediments on the settler surfaces, b) the percentage of this settled material which stays just where it is, c) the percentage of the settled material which slides down into the sump where it is assumed to be sheltered from the flow, and finally d) the percentage which is entrained by the flow and re-mixed at the tail edges of the plates. All these effects are to be expressed as a function of (mainly) flow, settler surface and sediment properties as well as on the test duration. In a second step, the effect of the vessel or tank has to be accounted for, too. Anyhow, within DESSIN we refrained from setting up such a model because it would imply a lot of additional assumptions where any verification would be doubtful in the light of the feeble and coarse available data.

In order to investigate more thoroughly the effects of sliding down of the particles as well as re-mixing at the trailing edge of lamellae, some tests were conducted where “tail strips” were glued to the trailing edge of the existing 40 mm lamellae with 60° inclination angle. Another set of tests used horizontal plates without “tail strips”. These additional tests will be described in the following chapter.

## 5 Experiments with “tail strips” on the lamella plates

### 5.1 Experimental set up and observations

The “tail strips” are 4 x 10 mm Perspex strips which were glued directly on the trailing edge of each lamella plate in both 40 mm lamella modules (60° inclination angle). It was assumed that sediment grains which are transported by the flow close to the lamella surface such as to drop finally off the trailing edge are captured by the strip and re-directed to slide down rather than to be re-mixed. Tests were made with 40mm plate spacing only.

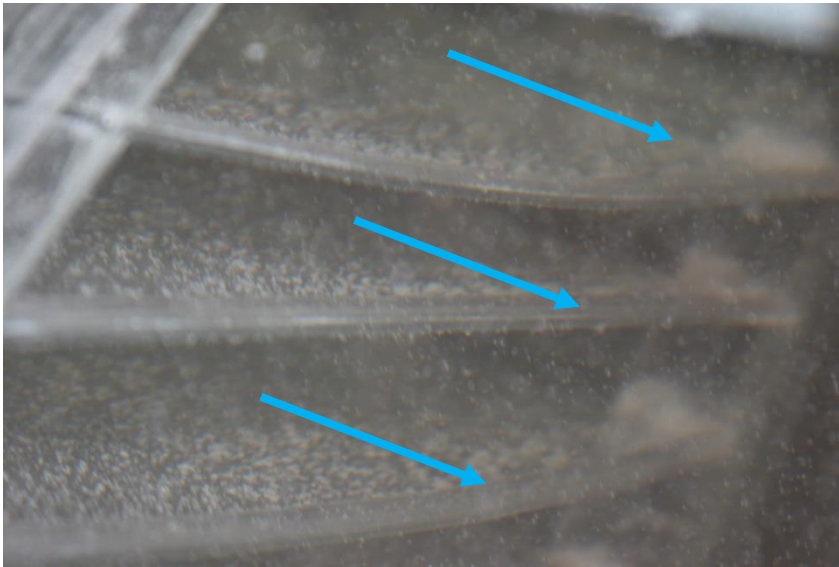

Figure 21: Close look on the “tail strips” of the second lamella module during the test. Some sediment grains are trapped by the strip, while others skip over it, transported by the flow.

As in the past tests, several series with different fluid density were made. For each density, the discharge varied between 3 L/s and approximately 8 L/s, typically in steps of 1 L/s. 25 kg of common kitchen salt (sodium chloride) were necessary to reach a density of 1,013 kg/L. Intermediate concentrations (1,003 kg/L, 1,007 kg/L and 1,010 kg/L) have also been studied. For the tests with salt water, it was necessary to measure in every experiment the density with a hydrometer since density decreased with time due to sweet-water rinsing of the experimental rig.

It was essential to describe the settling process a bit closer. To observe it, the well-visible sediment grains themselves were used as a tracer. When needed, a colouring agent was also injected in the flow. The general behaviour of sediments is the same for different flows: Sediment is transported by the flow and when the grains come into contact with the plates, they are deposited. It was very difficult to observe any sliding-down movement of sediments because it is a slow process. Anyway, it could again be observed that already deposited sediment grains are still transported in the direction of flow in a rolling manner.

The two modules are arranged one after another so that the plates were flush with a small gap between. For a small discharge of 3 L/s or 4 L/s, however, very few sediment grains arrive on the second module. So, the tail strips on the second module play a negligible role. Furthermore, as it

was difficult to observe the trailing edges of the first module, we had to look at a higher flow to understand the role of the strips.

For a discharge of approximately 5.5 L/s, sediments reached in significant quantity the second module and the strips. They grouped together in flakes along the length of these strips (Figure 21).

At a flow of 7 L/s, sediment gathered in flocks and tended to go over the edge, because of the speed of the flow. However, some particles slid downward along the edge. Once at the bottom, some sediment was again mixed by the flow and deposited on the floor of the basin.

## 5.2 Results

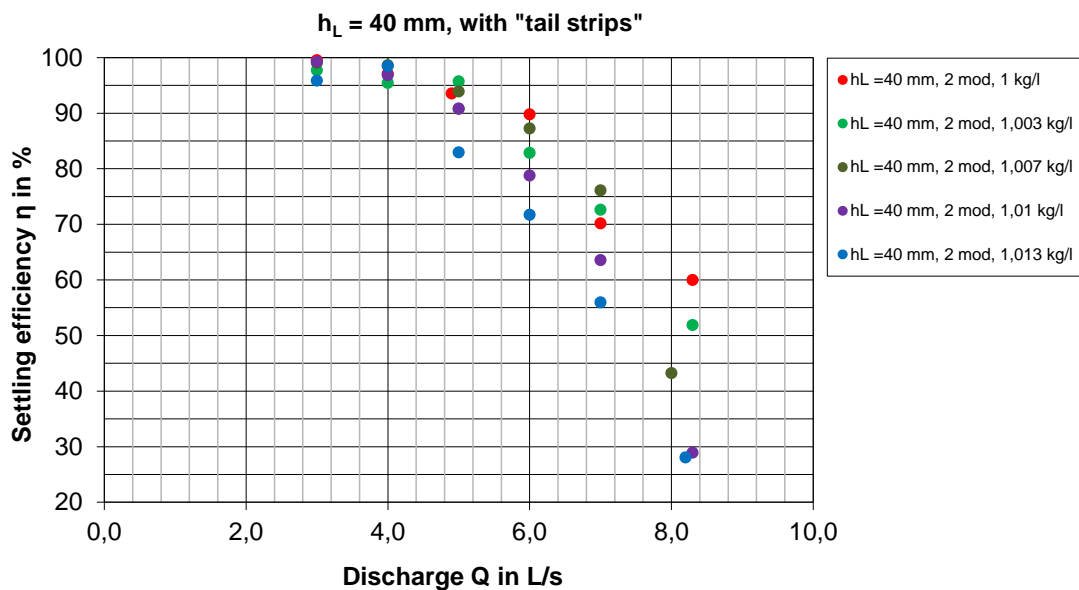

Figure 22: Raw data of efficiency vs. flow for modules with “tail strips”. All tests were made with  $h_L = 40 \text{ mm}$  and two modules.

From Figure 22, the already known dependency of settling efficiency on the flow and also on the fluid density can be seen. Again, experimental scatter is evident, but the results show a consistent pattern.

Figure 23 shows these data again in the already known dimensionless form where the surface loading  $Q/(B \cdot L)$  is calculated using the flume bottom area (cf. Figure 18, right bottom diagram). There is again a unique cluster with few scatter. The synthetic curve from Eq. ( 12 ) was again fitted to the data. The best fit for the parameter  $C$  is  $C = 0.878$ . If this is compared with  $C_0 = 1.177$  for the flume without any lamella modules from Table 2, we get an apparent increase in settling surface of  $(C_0/C) - 1 = 34.1 \%$ . This is a somewhat smaller value than  $37.0 \%$  for two  $40 \text{ mm}$  modules without “tail strips”. Seemingly, the strips do not increase the *overall* performance of the investigated geometry

of cross-flow lamella settlers with this particular model sediment and within the investigated range of surface loadings. However, due to the lack of data, this statement must not be generalized.

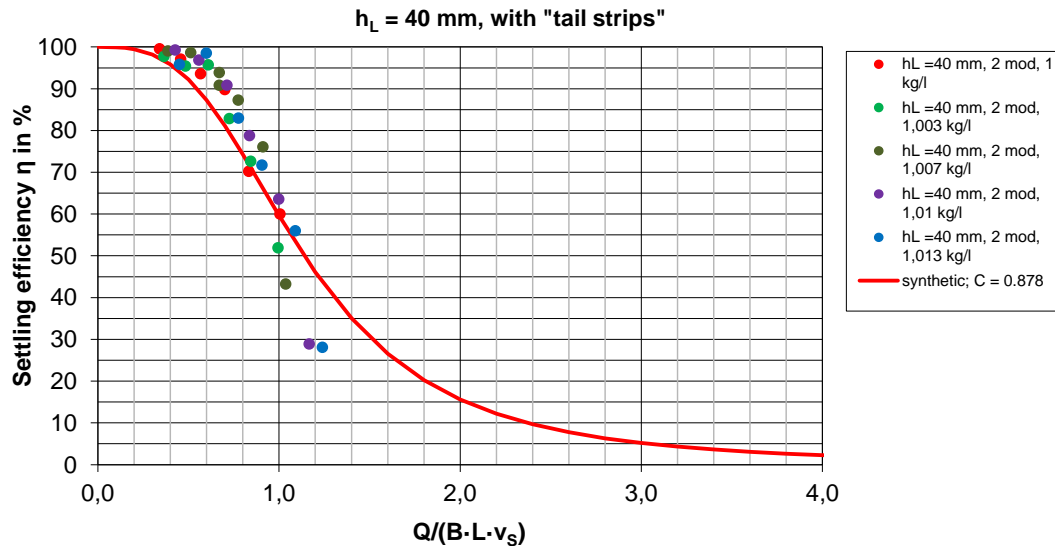

Figure 23: Dimensionless plot including a fitted synthetic curve

From Figure 23, however, it can be seen that Eq. ( 12 ) does not follow the data points with “tail strip” as well as it did in Figure 18, right bottom diagram. Instead, the data points show a better efficiency at low  $Q/(B \cdot L \cdot v_s)$  values, i.e. at low flows, while at higher flows, the measured performance falls short of the synthetic curve. This is an interesting fact. It confirms the observations already mentioned that sediments are trapped by the “tail strips” up to a certain flow where an onset of transport over the “tail strips” takes place. This means that “tail strips” will indeed improve the settling performance for low flows, as long as the lamella settlers are not surcharged.

Other appurtenances in order to encourage sliding down of settled sediment particles and to prevent entrainment by the flow have not been investigated, such as e.g. the use of corrugated plates rather than flat inclined plates.

The following statements can be made:

- Tail strips are not sufficient to suppress the re-entrainment and transport of already settled grains over the trailing edge of the lamella plates. However, a somewhat improved settling efficiency may be noted for small flows.
- The statement holds only for the well-rolling model sediments used here. It must not be generalized for real sewage-borne sediments.



## 6 Experiments with horizontal plate settlers

In order to get a better insight in the settling and re-mobilisation processes, also two horizontal plate settler modules were built and tested in the experimental rig. Different than with the 60° inclined plate settlers, settled sediment cannot slide down, but may be transported by the flow, anyway. The horizontal plates did not feature “tail strips”.

For a horizontal plate settler, the projected settling area equals the total plate area. Thus, a horizontal plate module with a lamella spacing of  $h_L = 80$  mm has approximately the same surface as a 60° inclined plate settler with  $h_L = 40$  mm. All tests were made with two modules and  $h_L = 80$  mm exclusively. Since the goal of the tests was to gain qualitative insight rather than to establish well-documented efficiency curves, the experimental program was kept small.

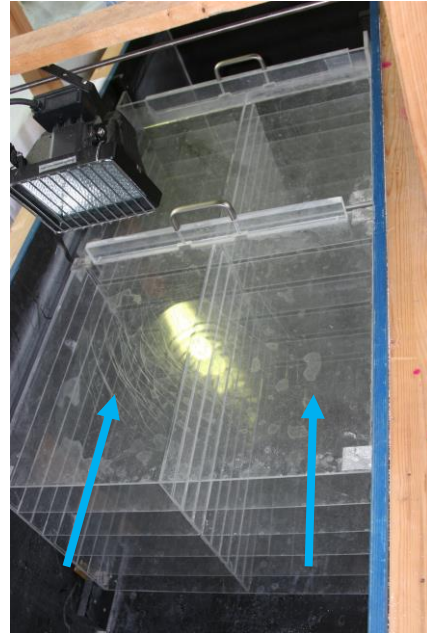

Figure 24: Two horizontal plate settlers in place

### 6.1 Experimental setup and observations

In this configuration, only two cases were studied: Water without salt and water with a density of 1,011 kg/L. For these two situations, as in the past tests, the discharge was varied between 3 L/s and 8 L/s.

The comprehension of the settling process was a major topic of these experiments, so the modules were again built from clear Perspex plates. Observation was somewhat hindered by large air bubbles trapped under the plates. Qualitatively, it could be observed that settled sediment collected on the plates, forming sediment dunes which indicated some transport of the material by the flow. It could be observed that these dunes moved slowly during the 1 h of test duration.

In Figure 25, the movement of sediments is shown. The two pictures were taken respectively 30 minutes and 60 minutes after the beginning of the experiment. Several observations can be made:

- The dune crests are curved rather than straight, and moreover not symmetrical, which is an indicator for a non-homogenous flow distribution
- The dunes are more advanced on the upper plates than on the lower, again indicating non-homogenous flow distribution (higher velocity above than below)
- On the upper plates, a larger amount of sediment is deposited than below (cf. Figure 26)

- The first module is collecting more sediment than the second (e.g. indicated by the fact that no dune formation is visible in Figure 26).
- The dunes are working as a sediment reservoir which is exposed to the flow. If the experiment will run for a longer time than 1 hour, it can be expected that still some sediment is entrained from the dunes. Since the sediment was added all at the same time at the beginning of each test run, the effect will yield an apparently decreasing efficiency with increasing test duration. The same effect was also observed in the detention basin without lamella modules, but less pronounced. It was not investigated more in detail.
- At the trailing edge of the lamellae, the sediment dunes are mixed into the flow again. Then, sediments are either deposited on a lamella of the second module or are taken by the flow to go in the overflow.

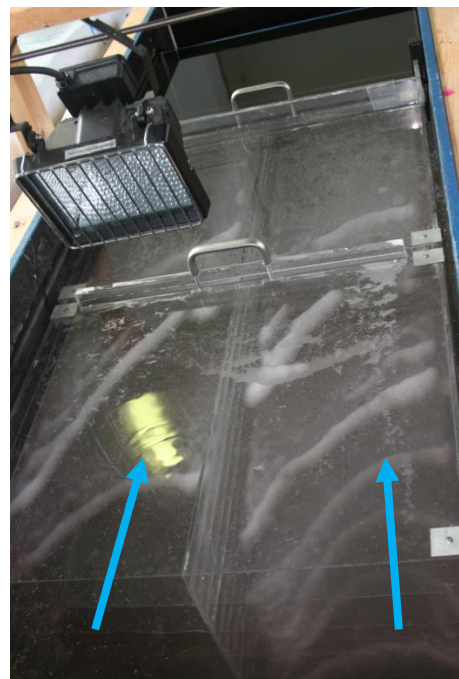
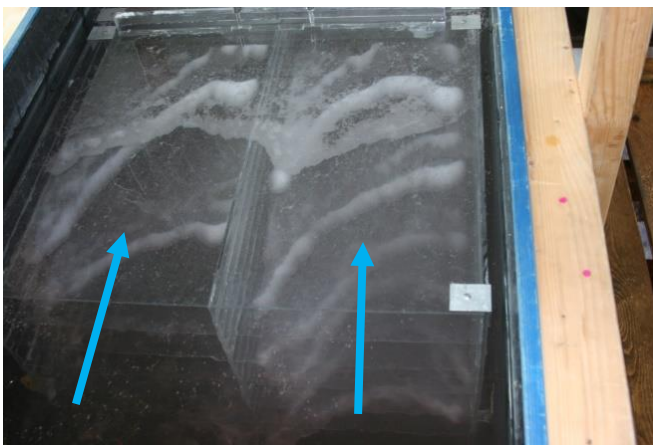

Figure 25: (above and right): Horizontal plate settler, 2 modules,  $h_L = 80 \text{ mm}$ ,  $Q = 4,0 \text{ L/s}$ . Evolution of sediment dunes with time. Left: 30 min, right: 60 min after beginning of test

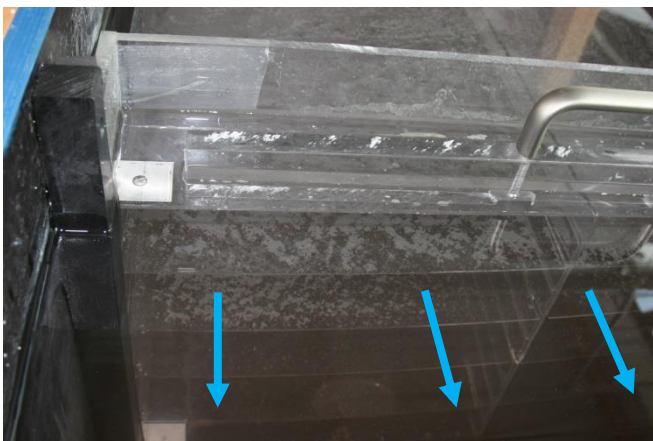

Figure 26 (left): Horizontal plate settler, 2 modules,  $h_L = 80 \text{ mm}$ ,  $Q = 4,0 \text{ L/s}$ . Trailing edge view. Sediment is transported over the smooth horizontal surfaces and re-mixed into the flow.

## 6.2 Results

As in the proceeding chapter, Figure 27 shows the efficiency  $\eta = f(Q)$  while the following figures are dimensionless. Again, the results are qualitatively such as expected, i.e. the efficiency is decreasing with increasing flow and with increasing fluid density (which yields a smaller settling velocity). The total projected area  $A_{proj,tot} = 4.2 \text{ m}^2$  for the horizontal plate clarifier with  $h_L = 80 \text{ mm}$  and  $A_{proj,tot} = 4.4 \text{ m}^2$  for the  $60^\circ$  lamellae with  $h_L = 40 \text{ mm}$  is approximately the same. Figure 28 shows a direct comparison of the obtained settling efficiencies with those of the cross-flow clarifier. The horizontal plate settler data show a somewhat smaller settling efficiency, but this is not very significant due to the large scatter and comparatively few data points and maybe also due to the somewhat smaller projected settling area  $A_{proj,tot}$ .

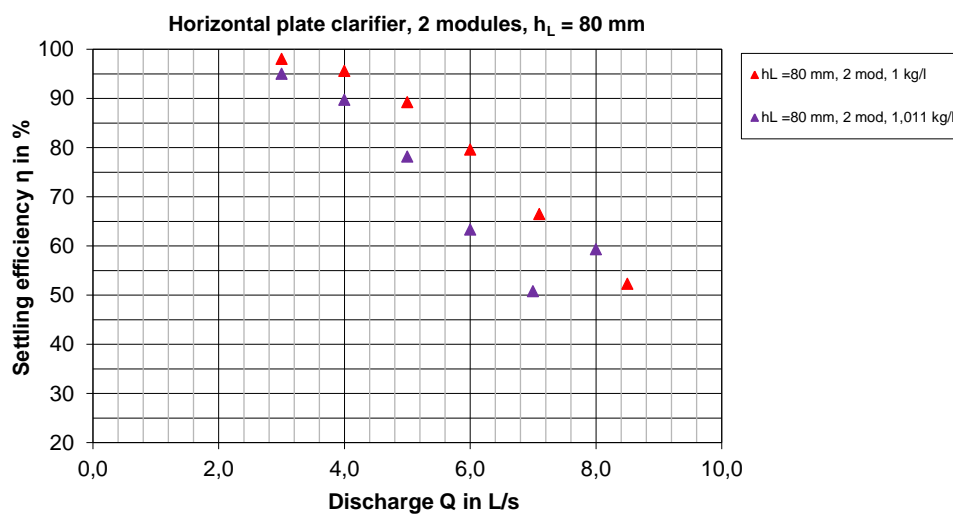

Figure 27: Raw data of efficiency vs. flow for a horizontal plate clarifier (two modules,  $h_L = 80 \text{ mm}$ )

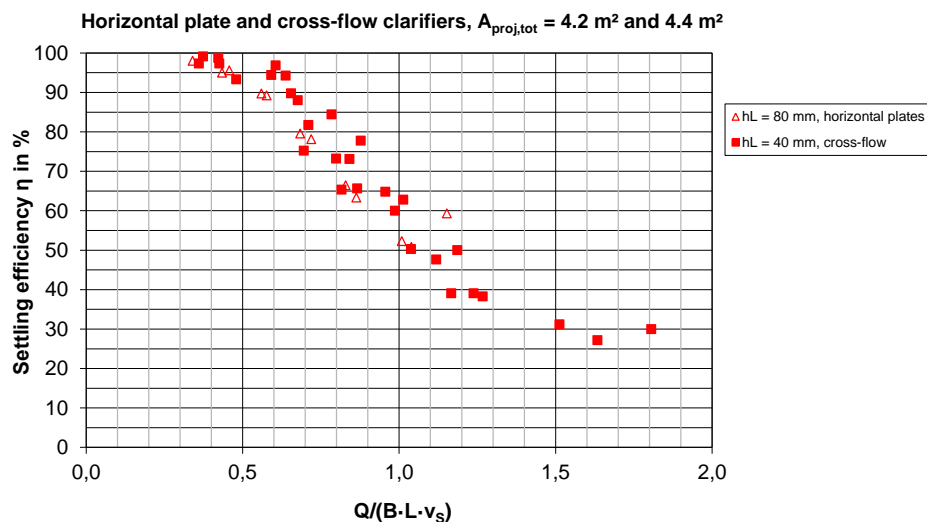

Figure 28: Comparison of a horizontal plate clarifier with cross-flow clarifiers, both for a total projected area of  $A_{proj,tot} = 4.2 \text{ m}^2$  and  $4.4 \text{ m}^2$ , respectively, and in the same experimental rig

The general pattern of the data points is again well approximated by Eq. ( 12 ), for a first glance also without showing the effects seen in the experiments with “tail strips” (however, in the present experiments, only small  $Q/(B \cdot L \cdot v_s)$  values were reached). The best-fit coefficient is  $C = 0.904$ . If this  $C$  value is compared with  $C_0 = 1.177$  for the flume without any lamella modules from Table 2, we get an apparent increase in settling surface of  $(C_0/C) - 1 = 30.1\%$  only (for comparison, 37.0 % for 60° lamellae without tail strips and 34.1 % with tail strips). This indicates also a somewhat worse settling performance of the horizontal plate settler.

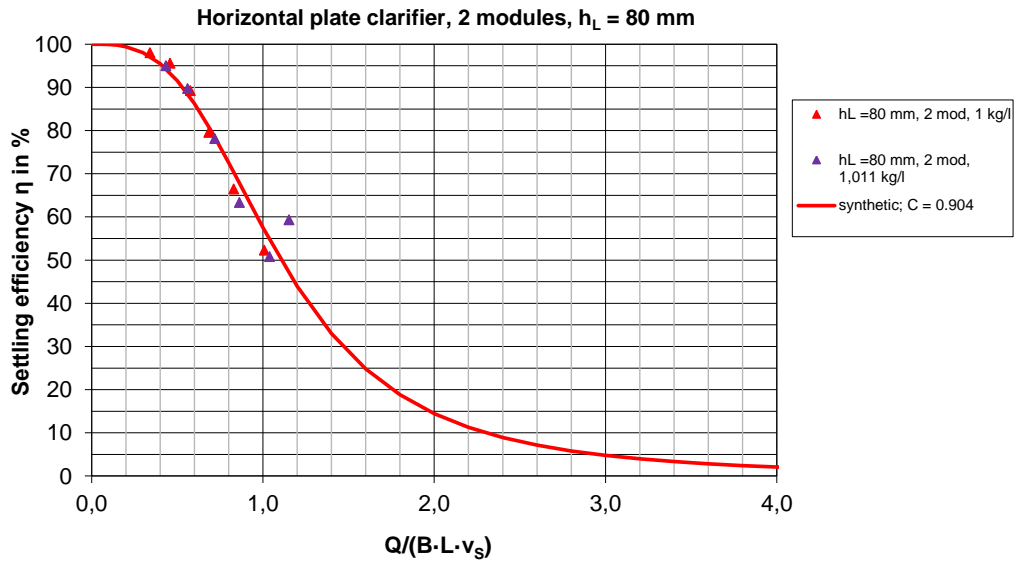

Figure 29: Modelled curve and data set for the horizontal lamella settlers

The following statements can be made:

- Horizontal plate settlers achieve the same projected settling surface  $A_{proj,tot}$  as inclined plates by using much less material or, respectively, by a larger plate spacing  $h_L$ . Compared with 60° lamellae,  $h_L$  can be doubled. This may be seen as a considerable advantage, as well economically as with respect to possible clogging.
- Using an approximately equal projected settling surface  $A_{proj,tot}$ , the investigated horizontal plate settler showed for the same flow a somewhat smaller settling efficiency for the model sediment, but the effect is minor. The effect of improved settling on the enlarged surface seems to work well, but obviously the transport of settled material on the smooth surfaces plays an important role.
- Again, these statements have been gained with the well-rolling and non-cohesive model sediment with rather large grains of uniform size. They must not be generalized.
- These results are not sufficient in order to decide whether horizontal plate settlers may be used successfully for combined sewage or stormwater treatment. The mentioned advantages, particularly large lamella spacing, may be thwarted by operational disadvantages,

e.g. the necessity of a suitable cleaning system. Settled sediment is much more exposed to the flow (and thus prone to re-entrainment during flow peaks) than it would be if collected at the tank bottom.

## 7 Comparison with results for upflow lamella separators

In the mentioned recently completed research project KIT (2015b), model tests on an upflow lamella separator were performed where a comparison of the results suggests itself. Since the evaluation there follows a somewhat different path, the data are re-evaluated in the following. Table 3 shows the technical data of the tests which were performed in nearly the same way and using the very same sediment (including addition of salt) as in the present project. The upflow lamella modules were arranged in a tub where the throughflow was not parallel, as in the present tests. Anyhow, the measured settling efficiency is again due to the lamellae as well as due to the tub, and it is necessary to try to separate both effects.

Table 3: Technical data of model tests from KIT (2015b) with upflow lamella settlers

volume of tub	ca. 1.0 m <sup>3</sup>
ground surface of tub, $A_{\text{tank}}$	ca. 0.96 m <sup>2</sup>
dimensions of lamella packet (projected view)	L:B:H = 1200 x 800 x 370 mm
inflow $Q$ (pumped)	max. 7.0 l/s
type of honeycomb modules	a) Leiblein LW 40, 40 mm height b) Leiblein LW 80, 80 mm height
Specific projected settling area of this honeycomb type at 60° inclination	a) 12.5 m <sup>2</sup> /m <sup>3</sup> b) 6.3 m <sup>2</sup> /m <sup>3</sup>
inclination angle	60°
total projected settling area $A_{\text{proj,tot}}$	a) 4.44 m <sup>2</sup> b) 2.22 m <sup>2</sup>
surface loading $q_A$ if homogenous throughflow through all honeycombs is assumed	a) 4.1 m/h @ 5.0 l/s b) 8.2 m/h @ 5.0 l/s

In KIT (2015b), it was assumed that *sedimentation takes place on the lamellae only*, thus the abscissa was given by the dimensionless property  $q_A/v_s$  where  $q_A = Q/A_{\text{proj,tot}}$ . In this case, two distinct patterns for 40 mm and 80 mm lamellae can be seen just as in Figure 14. The diagram is reproduced in Figure 30.

This graphics may serve for a first direct comparison of the upflow settler data if the abscissa values are computed using the total projected area of the lamellae,  $A_{\text{proj,tot}}$ , and neglecting the effect of the tub. The result is shown in Figure 31 where all data points of experimental runs with a different fluid density are shown in the same colour.

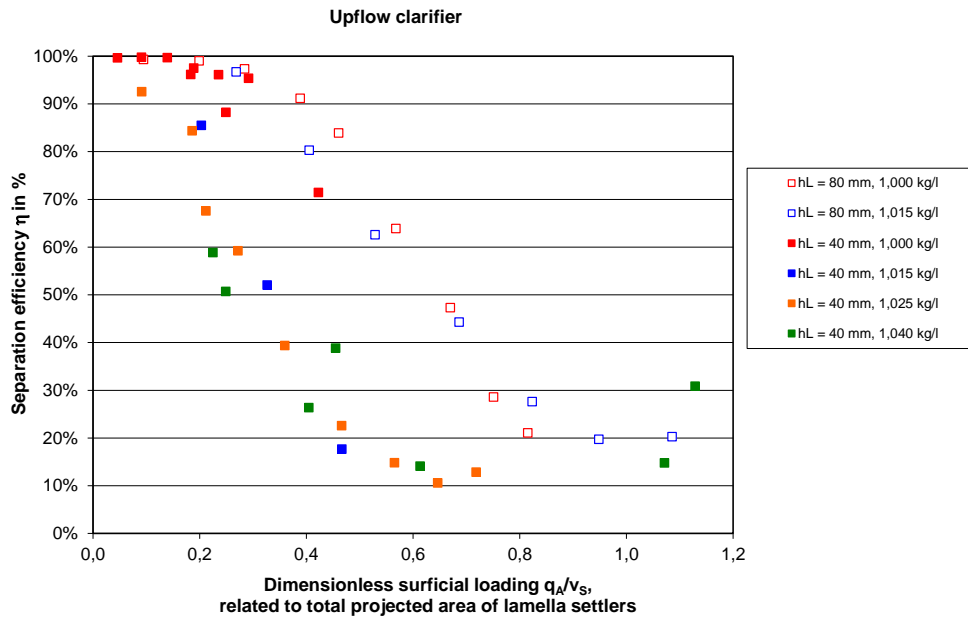

Figure 30: Settling efficiency of an upflow lamella separator as function of  $q_A/v_s$  (from KIT 2015b)

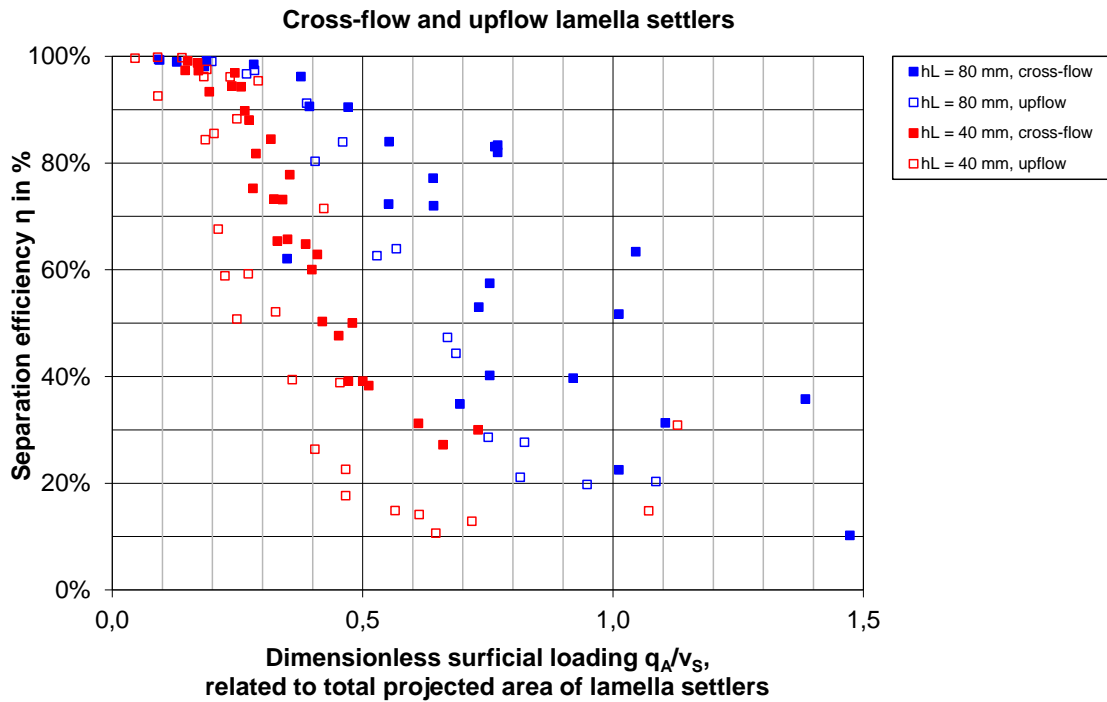

Figure 31: Comparison of cross-flow and upflow lamella settler efficiencies, both with approximately equal settling areas ( $A_{proj,tot} = 4.4 \text{ m}^2$  at 40 mm lamella spacing and  $2.2 \text{ m}^2$  at 80 mm, for both types)

It can be seen that the tests with the cross-flow clarifier revealed a significantly higher settling efficiency than those with the upflow unit, up to the double value which is very pronounced. Anyhow, it is doubtful that this improved sedimentation efficiency is due to the lamella arrangement: it has been shown already that the efficiency of an experimental rig is due to the lamella modules as well as due to the tub or basin in which they are installed. Both are not comparable in the two research projects. The basin used in the present report shows a near-parallel throughflow while the flow in the tub used in KIT (2015b) was three-dimensional due to the upflow arrangement of the modules. Moreover, the present basin is also considerably larger than the tub (ground plane area L·B = 1.78 m<sup>2</sup> compared with A<sub>tank</sub> = 0.96 m<sup>2</sup> in the past tests). If we assume sedimentation in the tub or basin as a non-negligible (or perhaps even dominant) effect in the model tests, this could explain the shown differences in settling efficiency. Anyhow, effects of re-mixing of sediment (which may perhaps be more pronounced at the upflow lamella modules) also contribute to the observed better performance of the cross-flow settlers.

As shown in Chapter 4.2, it is alternatively possible to compute the abscissa value using the tub ground plane surface (A<sub>tank</sub> or L·B) rather than the projected lamella surface A<sub>proj,tot</sub>. In a diagram like this, the implicit assumption is made that *sedimentation takes place mainly in the tub* (and it should be investigated whether there is an increase due to the lamellae). The result is shown in Figure 32.

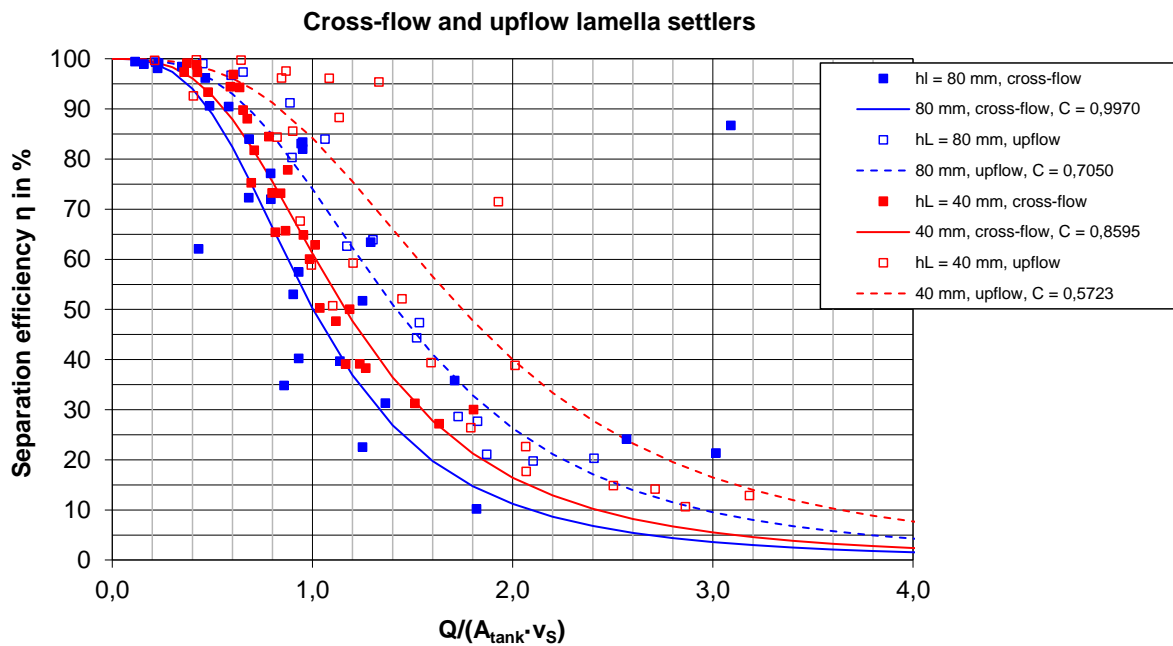

Figure 32: Comparison of cross-flow and upflow lamella settler efficiencies, other abscissa, including fitted synthetic curves

We see the same data points, but now the data from the upflow settler show a somewhat larger efficiency than those of the cross-flow lamella clarifier of the present investigation. Anyhow, the



difference between both separator types is not quite as large as in Figure 31. Of course, if we consider that the plan surface  $A_{\text{tank}}$  is considerably larger for the cross-flow than for the upflow model setup, data points with the same discharge are more to the left for the cross-flow and more to the right for the upflow tests. Again, this may explain the observation if an efficiency of the same order of magnitude is assumed for equal flow (the model sediment properties as well as the total lamella surface were equal in both tests). To suppress the effect of data scatter, again curves were fitted into the data as shown in Chapter 4.2, but for both types of settlers.

In this mode of presentation by an one-parameter curve,  $C$  will characterize the performance unambiguously. In Chapter 4.2,  $C$  was computed using Eq. ( 12 ). To investigate the increase in sedimentation performance by the lamellae, the ratio  $C/C_0$  could be interpreted as apparent increase in settling surface. This approach is also evaluated for comparison of both lamella settle types in Table 4 and Figure 33.

Table 4: Comparison of apparent increase of settling area for upflow and up flow lamella separator tests

	Cross-flow lamella separator			Upflow lamellae		
	Without modules	2 modules $h_l = 80 \text{ mm}$	2 modules $h_l = 40 \text{ mm}$	Without modules	$h_l = 80 \text{ mm}$	$h_l = 40 \text{ mm}$
Total area of flume $L \cdot B$ in $\text{m}^2$	1.78	1.78	1.78	(fictitious)	0.96	0.96
Projected area of lamellae $A_{\text{proj,tot}}$ in $\text{m}^2$	0.00	2.20	4.40		2.22	4.44
$A_{\text{proj,tot}} / A_{\text{tank}}$	<b>0.00</b>	<b>1.24</b>	<b>2.47</b>		<b>2.313</b>	<b>4.625</b>
$C$ value	1.177	0.997	0.859	0.918	0.705	0.572
$C_0/C$	1.000	1.181	1.370	(calculated)	1.302	1.604
Apparent increase in settling area in %	<b>0.0</b>	<b>18.1</b>	<b>37.0</b>		<b>30.2</b>	<b>60.4</b>

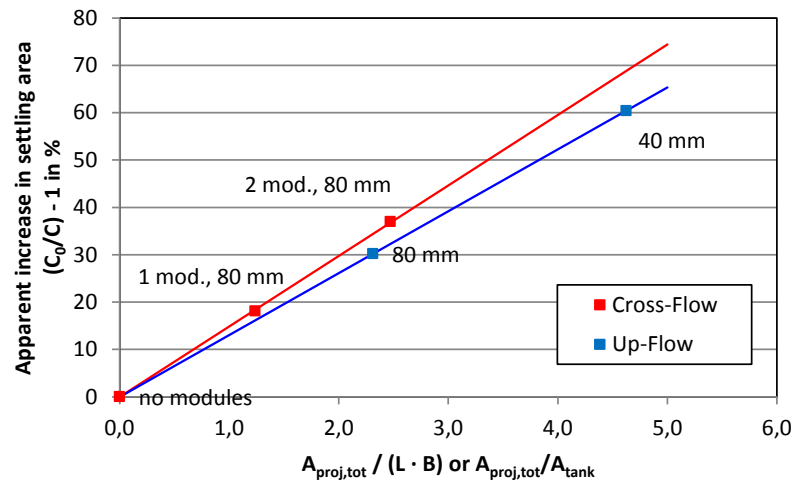

Figure 33: Apparent increase in settling area for cross-flow and up-flow lamella separators. The abscissa is the ratio of projected settler surface to the plan surface of the tank or vessel in which the lamellae are inserted.

If we consider the red data valid for the cross-flow settler, we can see a nearly linear increase in the value  $(C_0/C - 1)$  as apparent increase in settling surface. This has already been pointed out in Figure 19. Since there are tests without any modules, there is also a data point in the origin of the diagram. For the blue data of the upflow settler, no such tests without lamellae are available (test runs with lamella packets removed would have made no sense there since the flow pattern in the model rig would have been completely different without the flow-stratifying effect of the lamella modules). Anyhow, formally two different  $C$  values can be obtained for 80 mm and 40 mm lamellae, assuming the plan area the tub of  $A_{\text{tank}} = 0.96 \text{ m}^2$ . The  $C_0$  value is unknown, and for producing the curve of Figure 33, a linear blue curve was assumed. This can be justified by assuming that a double real projected lamella surface will cause the double apparent increase in settling area. Moreover, the red line shows also this linearity, resulting from  $C$  and  $C_0$  values which were determined there by experimental results. We get  $C_0 = 0.918$ .

Under this approach, finally, it is possible to make a comparison between both lamella settler types. The steepness of the linear curves in Figure 33 includes all effects such as sediment re-mixing. We can see that the apparent increase in settling surface is somewhat larger for cross-flow lamella settlers than for upflow settlers. Figure 33 gives an advantage in the order of magnitude if somewhat more than 10 % for the cross-flow settler. This may be a consequence of the fact that sliding down and re-mixing of sediments is somewhat more pronounced in an upflow lamella separator than in a cross-flow unit.

Anyhow, this result should not be over-interpreted since the advantage is not too large and the comparison was based on somewhat uncertain assumptions and large data scatter.

For prototype size settlers, it may be taken into account that the ratio of projected lamella surface to the plan area of the tank is much larger than in the model tests, due to the fact that the lamella spacing in the tests was 40 mm and 80 mm, the same value which is chosen in prototype lamella arrays. The experimental rig used in the model tests may be regarded as a scale model of a prototype CSO tank where  $M_L$  is the length scale with, say,  $M_L = 1:10$ . Then, the floor area  $A_{\text{tank}} = L \cdot B$  will be scaled with  $M_L^2 = 1:100$  and the tank volume with  $M_L^3 = 1:1000$ . It can be shown that for the same lamella spacing  $h_L$  in prototype and model, the ratio  $A_{\text{proj,tot}}$  is scaled also as  $M_L^3 = 1:1000$ , while the ratio  $A_{\text{proj,tot}} / (L \cdot B)$  is scaled as  $M_L = 1:10$ . If the linear behaviour of Figure 33 is extrapolated, we will get for a prototype tank 10 times as large as the model, equipped with 80 mm lamellae, an apparent increase in settling area of around 350 %.

We should be well aware that the result resembles the performance with well-rolling model sediment only. For real sewer sediment with probably less tendency to slide down, a different performance is possible. On the other end of the scale, an idealized sediment may be assumed which "sticks" at the lamella surfaces without sliding down or being remobilized. Then, a behaviour close to theory is expected where the apparent increase in settling surface is equal to the lamella surface. Probably there no difference can be found between both types of settlers.

Summarily, the following statements can be made:

- Even if some assumptions had to be made, the results of both research projects on model tests on cross-flow and upflow lamella separators could be compared.
- Results indicate that the cross-flow lamella settler reveals a somewhat better performance than the upflow settler of the same projected surface, even if the difference is minor.
- The tests have been made with idealized well-rolling sediment with large grains. Extrapolation to real sewer sediments is problematic, but there is some evidence that for real sewer sediment both settler types will show an equal performance.

This chapter should compile finally the main findings of the DESSIN model tests on cross-flow lamella settlers. The concept of model tests was given by the idea that the approach should be close to the tests from the past project on upflow settlers. Moreover, like at any research project, budget and time restrictions called for a small model test unit and a limited program, so any basic research e.g. on sediment properties was not within the scope of the DESSIN project.

The lessons learned from the model tests can be summed up as follows:

1) The use of well-rolling “ideal” model sediment gave good insight in the basic processes of lamella settler operation.

2) In most literature on lamella settlers, it is assumed that sediment removal from the throughflow is governed mainly by the process of sedimentation, putting the focus nearly exclusively on sedimentation theory. However, the findings of the present model tests indicate that some other effects play an even more important role on the overall separation performance:

- a) More or less pronounced sticking of sediment to inclined (smooth or rough) surfaces
- b) Sliding down of particles, either as single grains or as fluff or flake aggregates, along such inclined surfaces
- c) Sediment transport close to the surface due to – and along with – the flow.

In addition, b) and c) may also cause re-mixing of particles into the flow, either at the bottom of an upflow settler or at the tail edge of the plates.

These effects are not yet understood in detail. The mechanism of cohesion of small sediment particles, i.e. possible sticking to each other or to the surface, may be the key clue. Further research aiming at an improvement of lamella settlers of any shape should focus on these questions.

3) Even if only the process of sedimentation is investigated, there is always an important effect or contribution by the vessel or tank in which lamella settler modules of any kind are installed. Both effects cannot be separated in model tests.

4) The originally intended goal was to set up dimensionless efficiency curves by the use of model test results. These curves should be suitable to predict also the performance of prototype lamella settlers. However, this ambitious goal could not be achieved.

Dimensionless efficiency results suggest that they can be scaled and then transferred also to sediment of different settling velocity or even such having a non-uniform distribution of settling velocity. Anyhow, because of the dominating non-sedimentation effects stated under 2), efficiency results predicted for real sediment in prototype CSO tanks are not reliable. This is due to the fact that

the sediment still can be characterized by its settling properties only and the secondary effects under 2) cannot be scaled properly yet.

5) The good news is that tests with real sewer sediments conducted in the mentioned former research project revealed considerably better separation efficiencies than predicted as above by model test data. Possible reasons for this observation are again the effects mentioned under 2):

- a) real sediment will stick to the settler surfaces more pronounced than the large well-rolling model sediment grains,
- b) sliding of sediment down the settler surfaces is hindered by sticking and also by flocculation processes. Possibly flakes will form which will not slide down (if this happens at all) before they have reached a certain size,
- c) the sediment transport is different to the model sediment (single large grains vs. flakes).

It is assumed that re-mixing of sediment into the flow due to b) and c) will be less pronounced than in the model tests.

In addition, it may be postulated

- d) that also the sedimentation process itself is affected by sediment cohesion since sediment flakes may have a larger settling velocity than the individual non-aggregated particles.

6) In the DESSIN project also tests on a prototype-scale cross-flow lamella settler are planned at Emscher and Hoffselva site. It is necessary that the separation efficiency results of these prototype tests are evaluated also with respect to the sediment properties, and that a comparison with the model results and also to the results of the former upflow settler prototype investigations are made.

- Andritschke, N. (2010): Lamellenfilter zur Regenwasserreinigung. *wwt* 2/2010, S. 41-42
- ATV (1980): Abscheider mit lamellen- und kastenförmigen Durchflussprofilen. Arbeitsbericht, ATV-Fachauschuß 2.5 (5/1980). *Korrespondenz Abwasser*, 27. Jhg., S. 773 ff.
- Binder, H., Wiesmann, U. (1983): Sedimentation in Lamellenabscheidern. Teil 2: Theoretische Lösungen für Parallelplattensysteme, Kreis- und Rechteckrohre sowie ein Vergleich mit Experimenten. *Aufbereitungstechnik* Nr. 3 (1983), S. 145-15
- Boogaard, F.C., Langeveld, J.G., Liefing, H.J., Kluck, J. (2010): Stormwater quality and removal efficiency rates of lamella filters. NOVATECH 2010, Lyon, Mai 2010
- Buer, Th., Dorgeloh, E. (2001): Ertüchtigung von Nachklärbecken durch den Einbau von Kreuzstromabscheidern. *KA – Wasserwirtschaft, Abwasser, Abfall* 2001 (48) Nr. 4, S. 500 ff.
- Buer, Th., Stepkes, H. (2004): Lamellenabscheider in Regenüberlaufbecken zur Mischwasserbehandlung. 37. Essener Tagung, 24.-26.3.2004. *Gewässerschutz-Wasser-Abwasser*, Heft 193, S. 34/1 - 34/18
- Camp, T. R. (1953): Studies of sedimentation basin design. *Sewage and Industrial Wastes*, Vol. 25, pp. 1-12
- Daligault, A. et al. (1999): Stormwater and lamella settlers: Efficiency and reality. *Water Science and Technology* Vol. 39, No. 2, pp. 93-101
- Dohmann, M., Hördemann, K.-W. (2003): Einsatz von Schrägklärern in Mischwasserbehandlungsanlagen. Schlussbericht zum BMBF-Forschungs- und Entwicklungsvorhaben 02WI9922. Institut für Siedlungswasserwirtschaft, RWTH Aachen
- Dorgeloh, E., Marggraff, M., Buer, Th. (1996): Vermeidung der Erweiterung von Nachklärbecken durch den Einbau von Lamellenabscheidern. 29. Essener Tagung, 13.-15.3.1996. *Gewässerschutz-Wasser-Abwasser*, Heft 156, S. 24/1 - 24/15
- DWA-A 166 (2013): Bauwerke der zentralen Regenwasserbehandlung und –rückhaltung – Konstruktive Gestaltung und Ausrüstung. DWA-Arbeitsblatt
- EC [European Commission] (2014): Frequently Asked Questions about FP7. [http://ec.europa.eu/research/fp7/index\\_en.cfm?lg=en&pg=faq&sub=details&idfaq=24311](http://ec.europa.eu/research/fp7/index_en.cfm?lg=en&pg=faq&sub=details&idfaq=24311)
- Fuchs, S., Mayer, I. (2010): Schrägklärer in der Regenwasserbehandlung – Wirksamkeit und betriebliche Randbedingungen. Bremen, DWA-Regenwassertage 2010
- Fuchs, S., Mayer, I., Haller, B., Roth, H. (2010): Einsatz von Schrägklärern in der Regenwasserbehandlung. *KA Korrespondenz Abwasser, Abfall* 2010 (57) Nr. 11, S. 1109-1117
- Fuchs, S., Mayer, I., Haller, B., Roth, H. (2014): Lamella settlers for storm water treatment – performance and design recommendations. *Water Science and Technology*, 69.2, pp. 278-285
- Fujisaki, K. (2010): Enhancement of settling tank capacity using a new type of tube settler. *Water Science and Technology* 2010 Nr. 62.6, pp. 1313-1220
- Glas, M., Störr, H. (2007): Schrägklärer in der Regenwasserbehandlung. Planung, Bau und erste Betriebserfahrungen. *KA – Abwasser, Abfall* 2007 (54) Nr. 5, S. 462 ff.
- KIT (2015a): Überwachung und Optimierung der Leistungsfähigkeit von Mischwasserbehandlungsanlagen. Teil 1: Analyse der Leistungsfähigkeit von Regenüberlaufbecken und Überwachung durch Online Messtechnik. Research project, Ministerium für Klimaschutz, Umwelt, Landwirtschaft, Natur- und Verbraucherschutz des Landes Nordrhein-Westfalen. Karlsruhe Institute of Technology (project coordinator), Schlussbericht (in print)

- KIT (2015b): Überwachung und Optimierung der Leistungsfähigkeit von Mischwasserbehandlungsanlagen. Teil 2: Optimierung der Leistungsfähigkeit von Regenüberlaufbecken mittels Schrägklärertechnologie. Research project, Ministerium für Klimaschutz, Umwelt, Landwirtschaft, Natur- und Verbraucherschutz des Landes Nordrhein-Westfalen, Karlsruhe Institute of Technology (project coordinator), Schlussbericht (in print)
- Krauth, Kh., Bondareva, O. (1999): Anwendung von Flockungsverfahren bei der Regenwasserbehandlung. Zwischenbericht Statusseminar BWPLUS, Forschungszentrum Karlsruhe, 9.-10.03.1999
- Ngu, H., Wong, K.K., Law, P.L. (2012): Optimization of circular plate separators with cross flow for removal of oil droplets and solid particles. *Water Environment Research*, Vol. 84, No. 4, pp. 299-304
- Schaffner, J., Morin, A., Steinhardt, J. (2010): Einsatz von dreidimensionaler numerischer Modellierung zur Optimierung von Regenwasserbehandlungsanlagen. Bremen, DWA-Regenwassertage 2010
- Schaffner, J., Pfeffermann, A., Eckhardt, H., Steinhardt, J. (2010): Inflow based investigations on the efficiency of a lamella particle separator for the treatment of stormwater runoffs. NOVATECH 2010, Session 2.3, Lyon, Mai 2010
- Schönberger, D. et al. (2001): Einsatz von Lamellenpaketen in Belebungsbecken zur Erhöhung des Trockensubstanzgehaltes. *KA – Wasserwirtschaft, Abwasser, Abfall* 2001 (48) Nr. 1, S. 54 ff.
- Steinhardt, J., Schaffner, J. (2007): Kosteneinsparung durch effektive Regenwasserbehandlung auf kleinstem Raum. *Kommunalwirtschaft* 9/2007, S. 612 f.
- Vasquez, J., Morin, A., Dufresne, M., Wertel, J. (2010): Optimisation de la forme des décanteurs lamellaires par la modélisation hydrodynamique 3D. NOVATECH 2010, Session 2.3, Lyon
- Weiss, G. (2014): Innovative use of lamella clarifiers for central stormwater treatment in separate sewer systems. *Water Science and Technology*, 69.8, pp. 1606-1611
- WFD (2000): Directive 2000/60/EC of the European Parliament and of the Council of 23 October 2000 establishing a framework for Community action in the field of water policy (Water Framework Directive). <http://eur-lex.europa.eu/legal-content/EN/TXT/?uri=CELEX:32000L0060>, visited 15-JAN-2015
- Yao, K.M. (1970): Theoretical study of high-rate sedimentation. *Journal of Water Pollution Control Federation*, 42, H. 2, S. 218 ff.



The research leading to these results has received funding from the European Union Seventh Framework Programme (FP7/2007-2013) under grant agreement no. 619039  
This publication reflects only the author's views and the European Union is not liable for any use that may be made of the information contained therein.

